

Flavour Physics and CP Violation

Nikhef

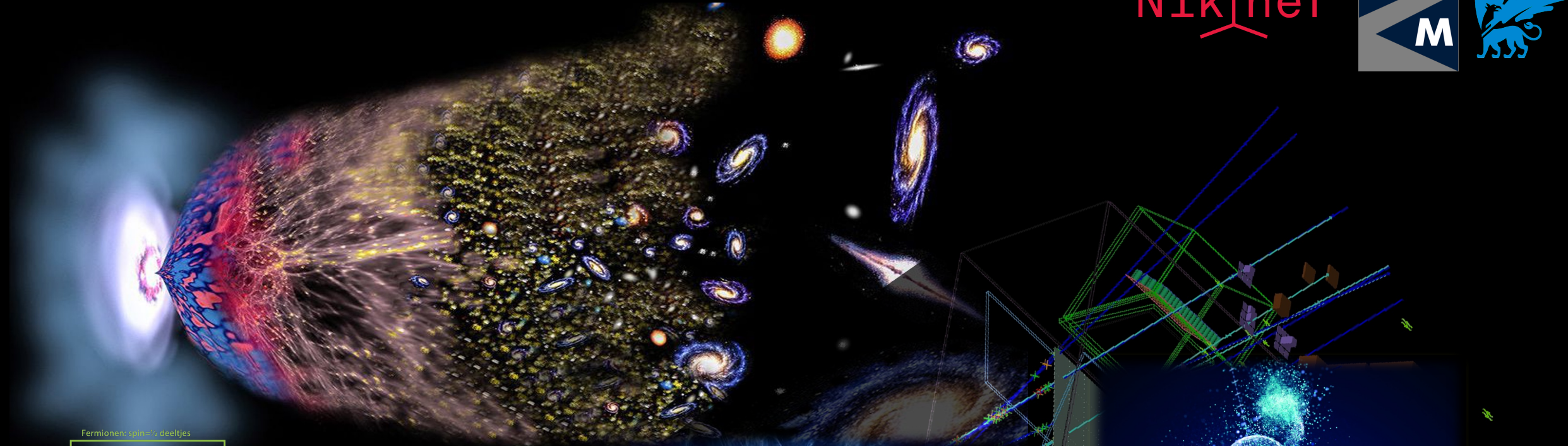

Fermionen: spin=1/2 deeltjes

Quarks		
u	c	t
d	s	b
1	2	3

bosonen: spin=1 deeltjes

Krachten	
Z	γ
W	g

Higgs field

Leptonen		
ν_e	ν_μ	ν_τ
e	μ	τ

H

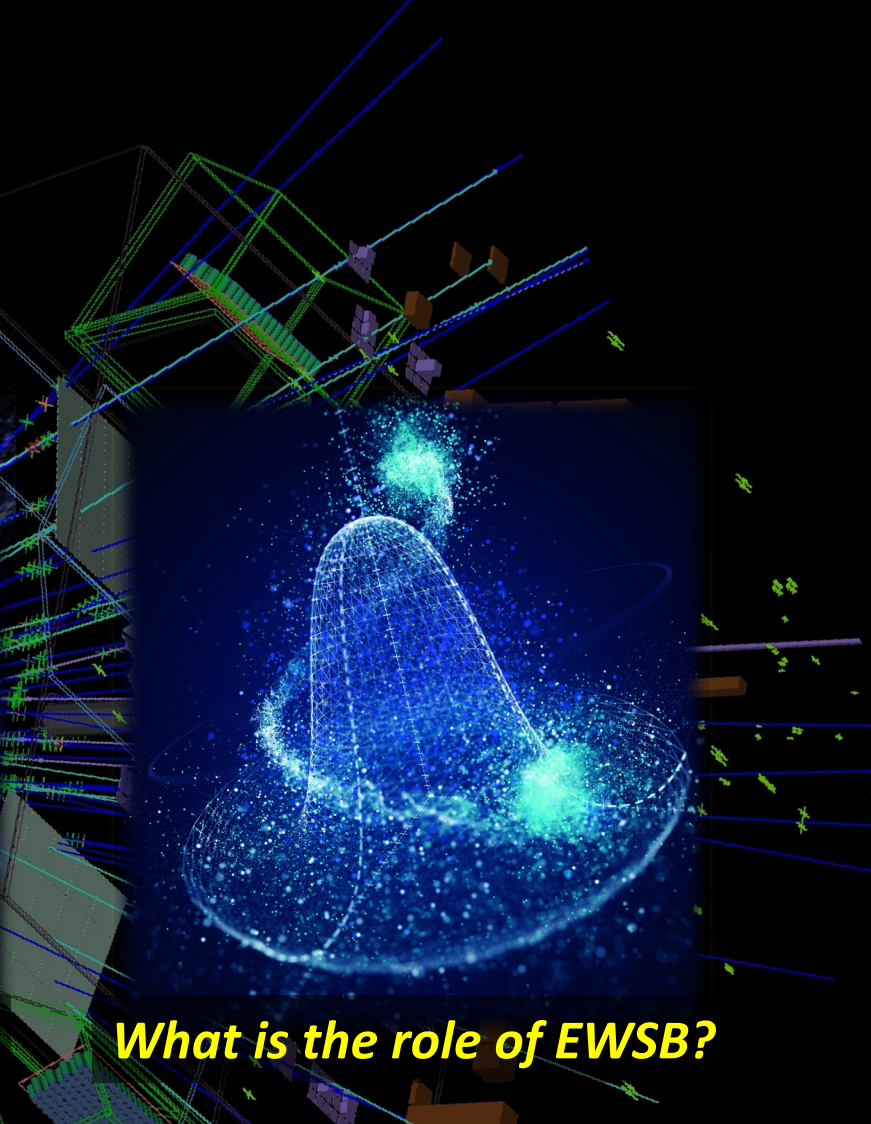
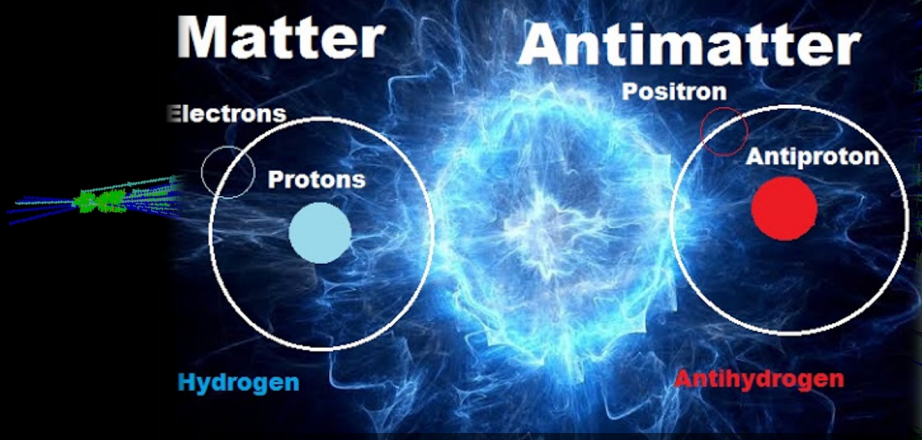

Why three generations of particles?

Why is there no antimatter?

What is the role of EWSB?

Contents:

1. Discrete Symmetries C, P and CP
2. CP violation in the weak force
3. How can we measure it?
4. The matter – antimatter asymmetry

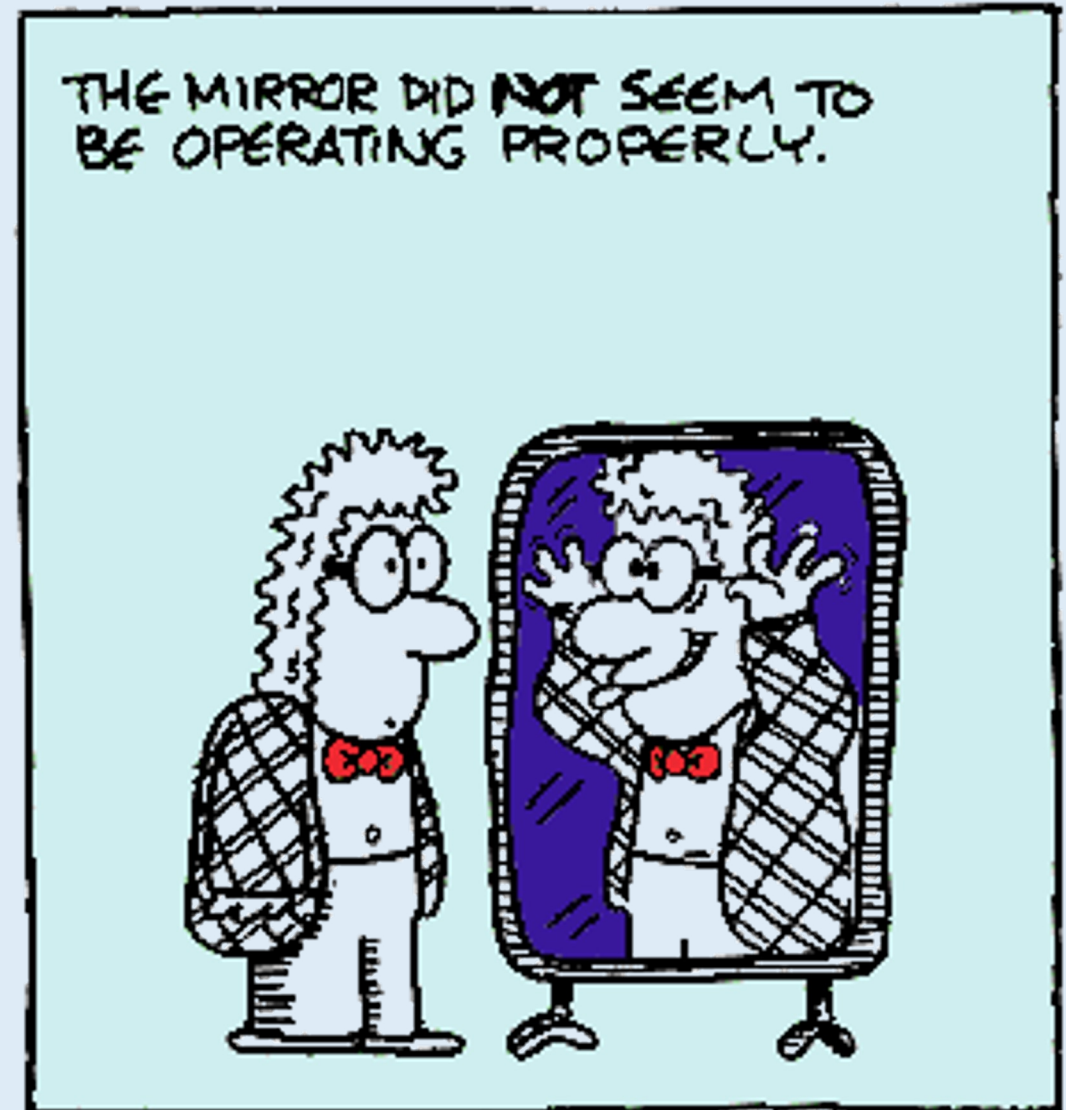

Contents:

1. Discrete Symmetries C, P and CP
2. CP violation in the weak force
3. How can we measure it?
4. The matter – antimatter asymmetry



C, P, T Discrete Symmetries

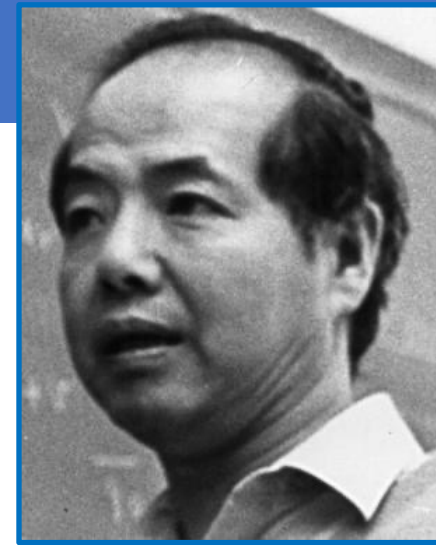

T.D.Lee: “The root to all *symmetry* principles lies in the assumption that it is impossible to observe certain basic quantities; the *non-observables*”

- Parity, P: *unobservable: (absolute handedness)*

- Reflects a system through the origin.
Converts right-handed to left-handed.
- $\vec{x} \rightarrow -\vec{x}$, $\vec{p} \rightarrow -\vec{p}$ (vectors) but $\vec{L} = \vec{x} \times \vec{p}$ (axial vectors)

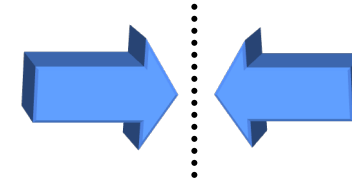

- Charge Conjugation, C: *unobservable: (absolute charge)*

- Turns internal charges to opposite sign.
- $e^+ \rightarrow e^-$, $K^- \rightarrow K^+$



- Time Reversal, T: *unobservable: (direction of time)*

- Changes direction of motion of particles
- $t \rightarrow -t$

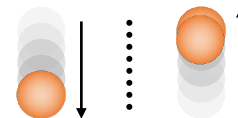

- CPT Theorem:

- All interactions are invariant under combined C, P and T operation
- A particle *is* an antiparticle travelling backward in time
- Implies e.g. **particle and anti-particle have equal masses and lifetimes**

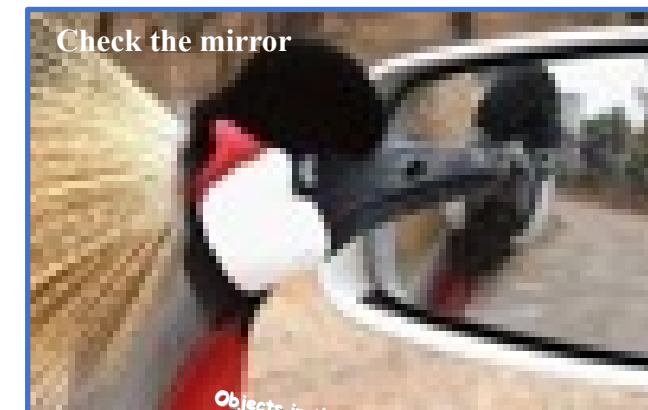

- Parity operator $P: \vec{x} \rightarrow -\vec{x}$

- Mass m $P: m = m$: “scalar”
- Force \vec{F} ($\vec{F} = d\vec{p}/dt$); $\vec{p} = m d\vec{x}/dt$ $P: \vec{F} = P: d\vec{p}/dt = -d\vec{p}/dt = -\vec{F}$: “vector”
- Acceleration \vec{a} ($\vec{a} = d^2\vec{x}/dt^2$) $P: \vec{a} = -d^2x/dt^2 = -\vec{a}$: “vector”
- Angular momentum $\vec{L}, \vec{S}, \vec{J}$ ($\vec{L} = \vec{x} \times \vec{p}$) $P: \vec{L} = -\vec{x} \times -\vec{p} = \vec{L}$: “axial vector”

- Parity: Newton’s law is *invariant* under P -operation (i.e. the same in the mirror world):

$$\vec{F} = m \vec{a} \xrightarrow{P} -\vec{F} = -m\vec{a} \Leftrightarrow \vec{F} = m\vec{a}$$

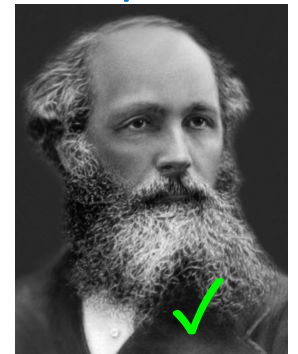

- Charge: Lorentz Force in the C -mirror world is *invariant*:

$$\vec{F} = q [\vec{E} + \vec{v} \times \vec{B}] \xrightarrow{C} \vec{F} = -q [-\vec{E} + \vec{v} \times -\vec{B}]$$

- Time: laws of physics are also *invariant* unchanged under T -reversal, since:

$$\vec{F} = m \vec{a} = m \frac{d^2\vec{x}}{dt^2} \xrightarrow{T} \vec{F} = m \frac{d^2\vec{x}}{d(-t)^2} \Leftrightarrow \vec{F} = m \vec{a}$$

- QM: Consider Schrodinger’s equation ($t \rightarrow -t$): $ih \frac{\partial \psi}{\partial t} = -\frac{\vec{\nabla}^2 \psi}{2m}$

Complex conjugation of the equation is required to stay invariant:

$$\psi \xrightarrow{T} \psi^*$$

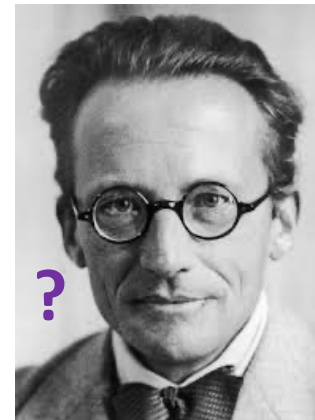

- Classical Theory is invariant under C , P , T operations; i.e. they conserve C , P , T symmetry
 - Newton mechanics, Maxwell electrodynamics.
- Suppose we watch some physical event. Can we determine unambiguously whether:
 - We are watching the event where all *charges are reversed* or not?
 - We are watching the event *in a mirror* or not?
 - Macroscopic biological asymmetries are considered *accidents of evolution* rather than fundamental asymmetry in the laws of physics.
 - We are watching the event in a *film running backwards* or not?
 - The arrow of time is due to thermodynamics: i.e. the realization of a macroscopic final state is *statistically more probable* than the initial state.



Parity Violation

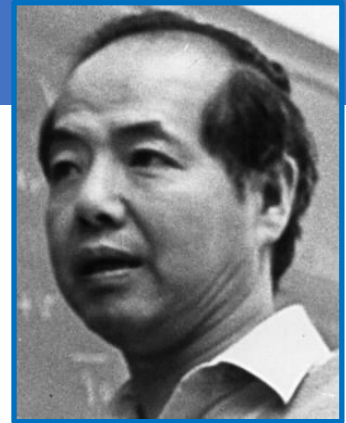

Before 1956 physicists were convinced that the laws of nature were left-right symmetric. Strange?

A “gedanken” experiment: consider two perfectly mirror symmetric cars:

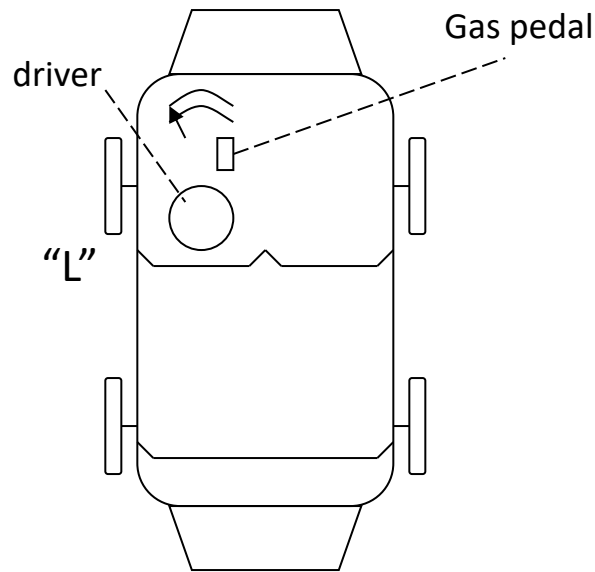

“L” and “R” are fully symmetric,
Each nut, bolt, molecule etc.
However the engine is a black box

Person “L” gets in, starts, 60 km/h
Person “R” gets in, starts, What happens?

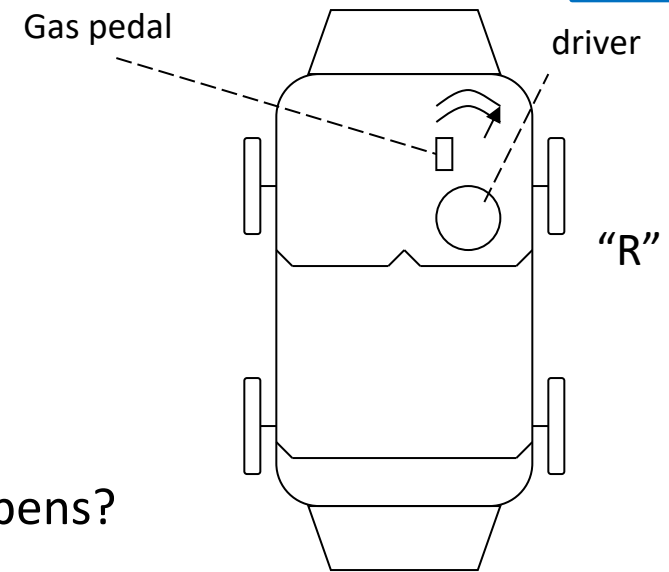

Phrased in another way: can you tell whether you are looking directly at the car or via a mirror?

Can you tell whether you are looking directly at the right-side car or via a mirror?

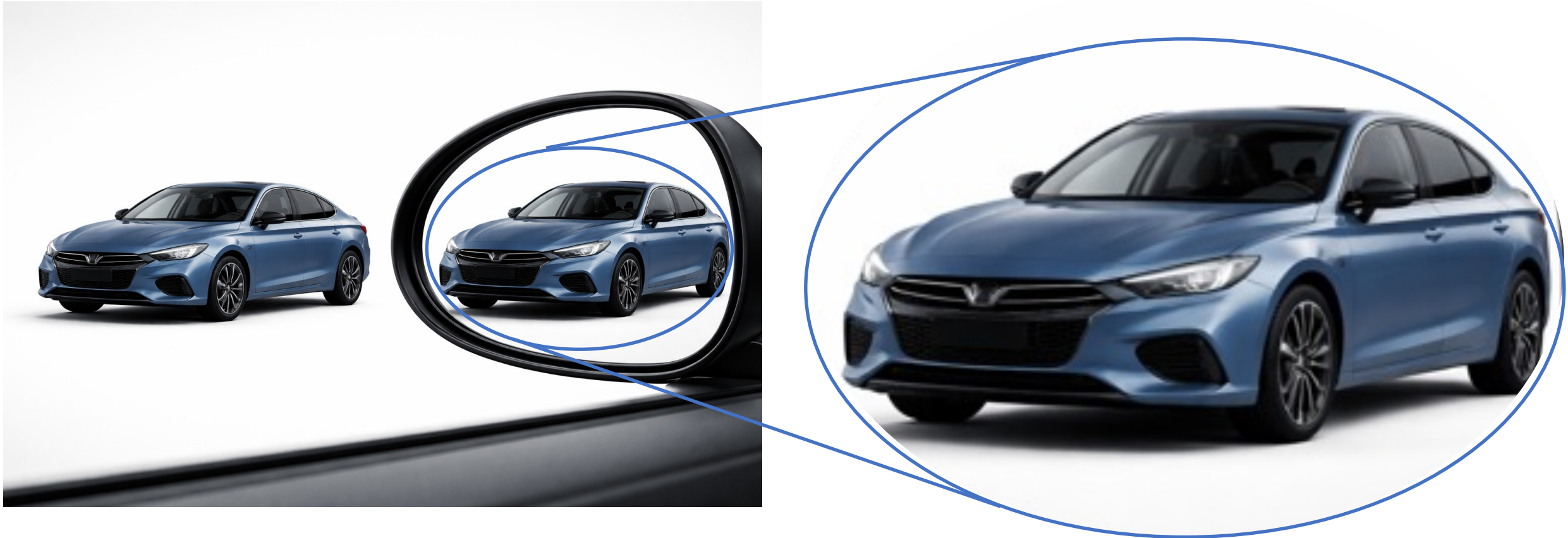

If **No** :Parity conservation, if **Yes**: Parity violation

Parity Violation

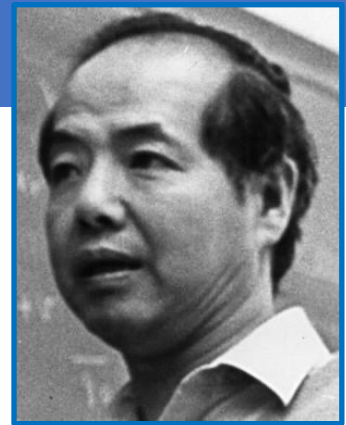

Before 1956 physicists were convinced that the laws of nature were left-right symmetric. Strange?

A “gedanken” experiment: consider two perfectly mirror symmetric cars:

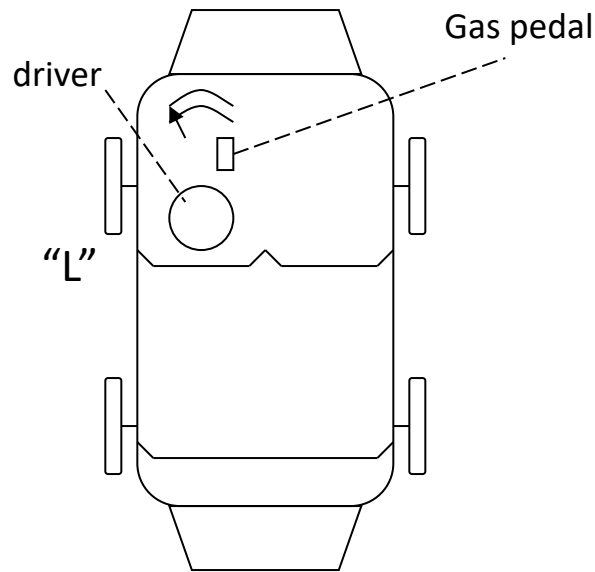

T.D. Lee

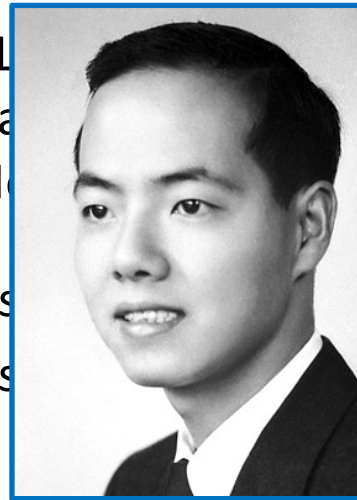

C.N. Yang

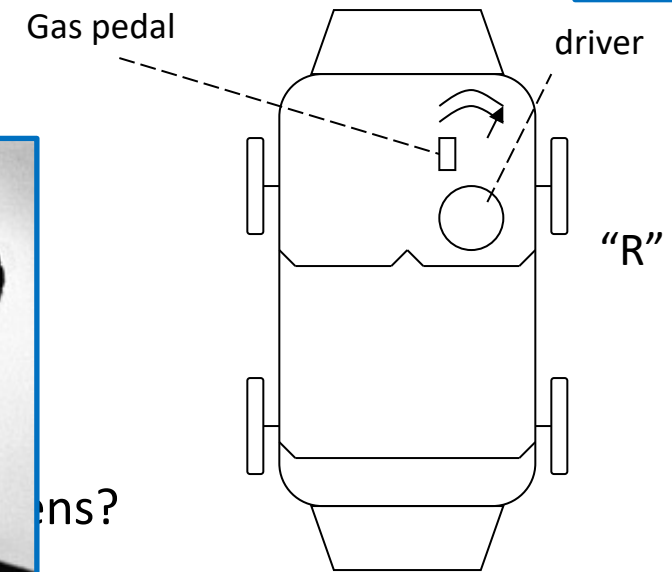
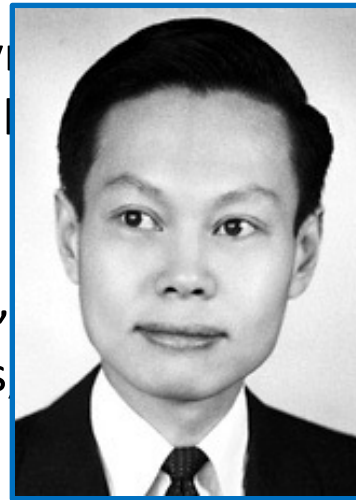

Phrased in another way: can you tell whether you are looking directly at the car or via a mirror?

What happens in case the ignition mechanism uses, say, $Co^{60} \beta$ decay?

Discovery of Parity Violation

Spin is pseudoscalar, P: $\vec{S} \rightarrow \vec{S}$

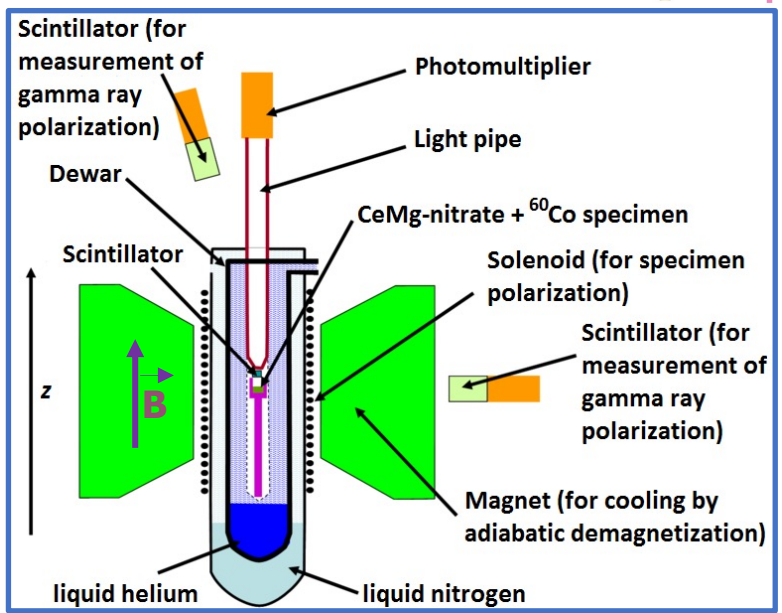
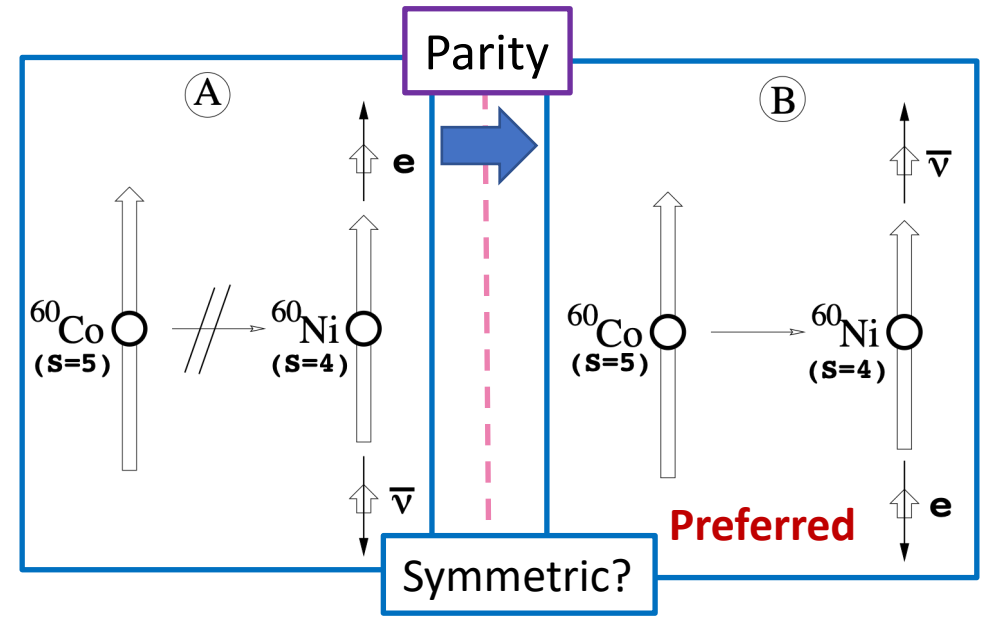
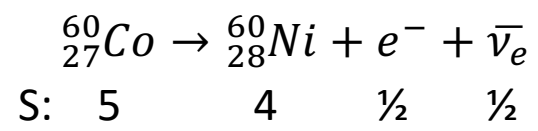
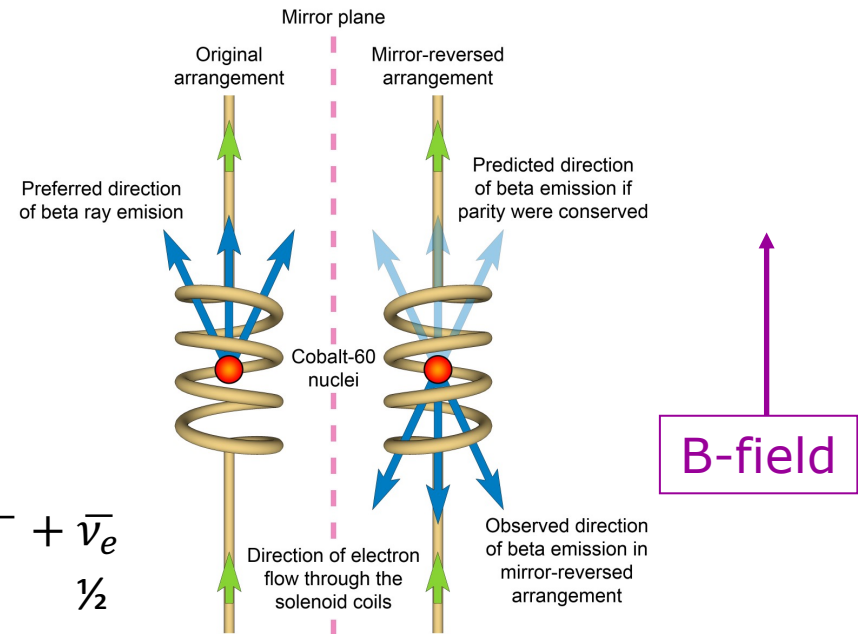

Is physics is parity invariant?

Only if electron decay rate is symmetric wrt spin direction!

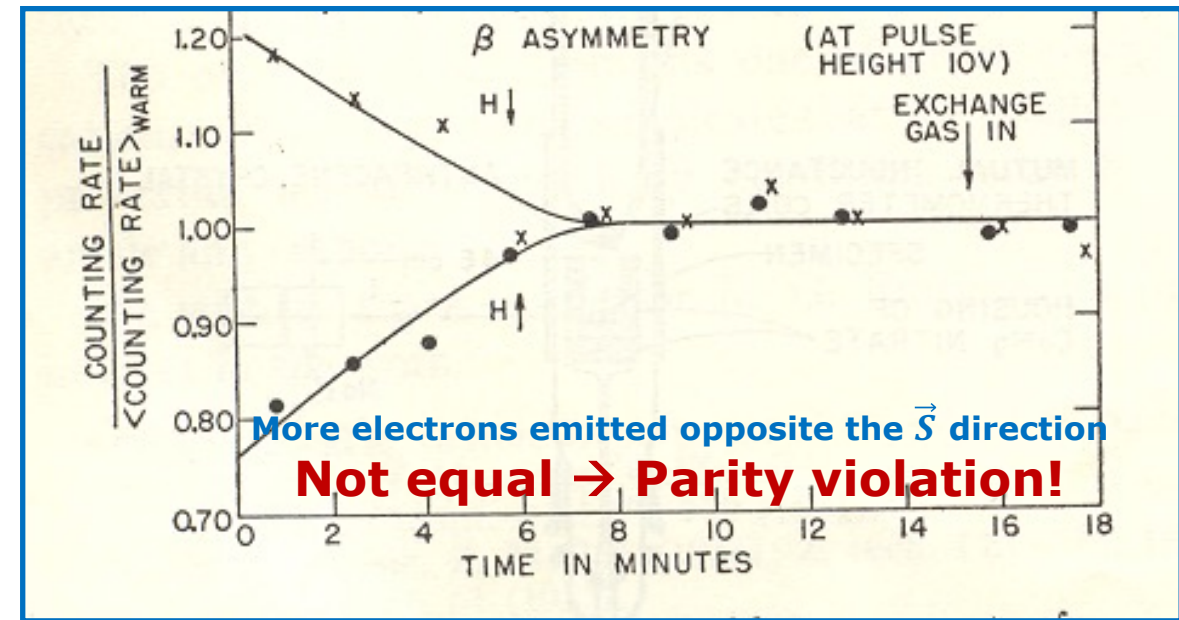

- Wu's experiment was shortly followed by another clever experiment by L. Lederman: Look at decay $\pi^+ \rightarrow \mu^+ \nu_\mu$
 - Pion has spin 0, while μ, ν_μ both have spin $\frac{1}{2}$
 - spin of decay products must be oppositely aligned
 - Helicity of muon could be + or – due to non-zero mass

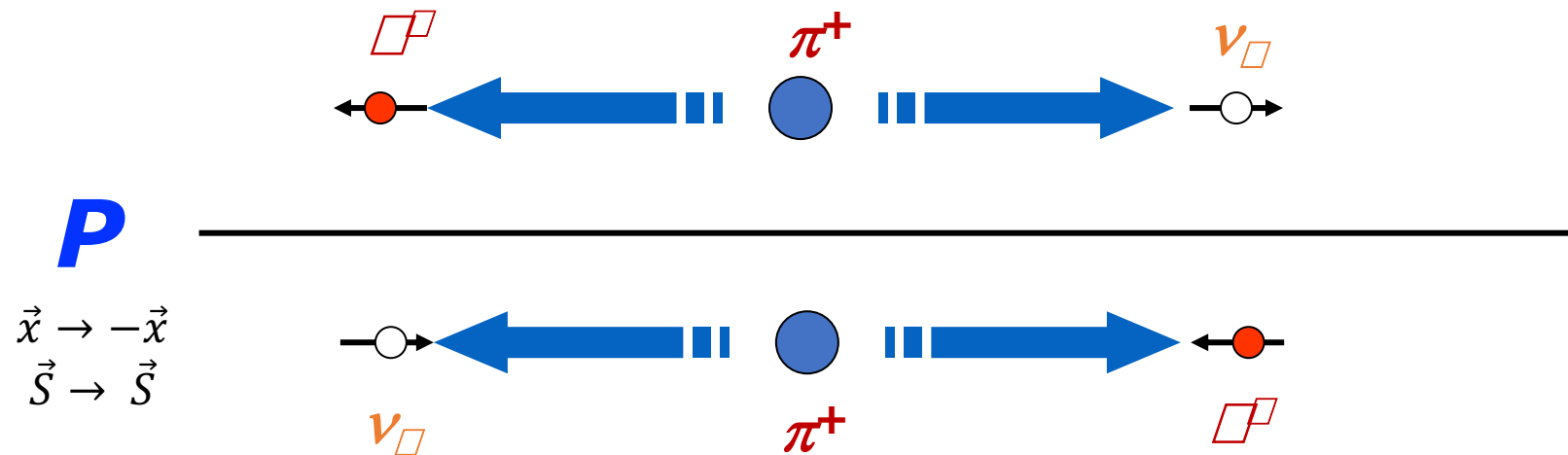

Do these happen at the same rate?

- Wu's experiment was shortly followed by another clever experiment by L. Lederman: Look at decay $\pi^+ \rightarrow \mu^+ \nu_\mu$
 - Pion has spin 0, while μ, ν_μ both have spin $\frac{1}{2}$
 - spin of decay products must be oppositely aligned
 - Helicity of muon could be + or – due to non-zero mass

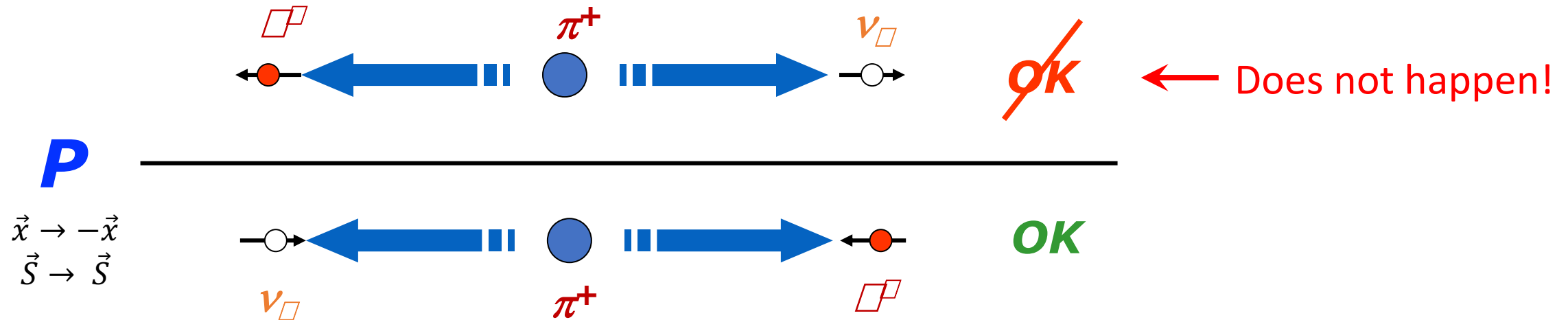

- Ledermans result: All neutrinos are left-handed

P symmetry is maximally violated

- C -symmetry

- The C (harge) conjugation is the operation that exchanges **particles and anti-particles** (not just electric charge)
- It is a discrete symmetry, just like P , i.e. $C^2 = 1$

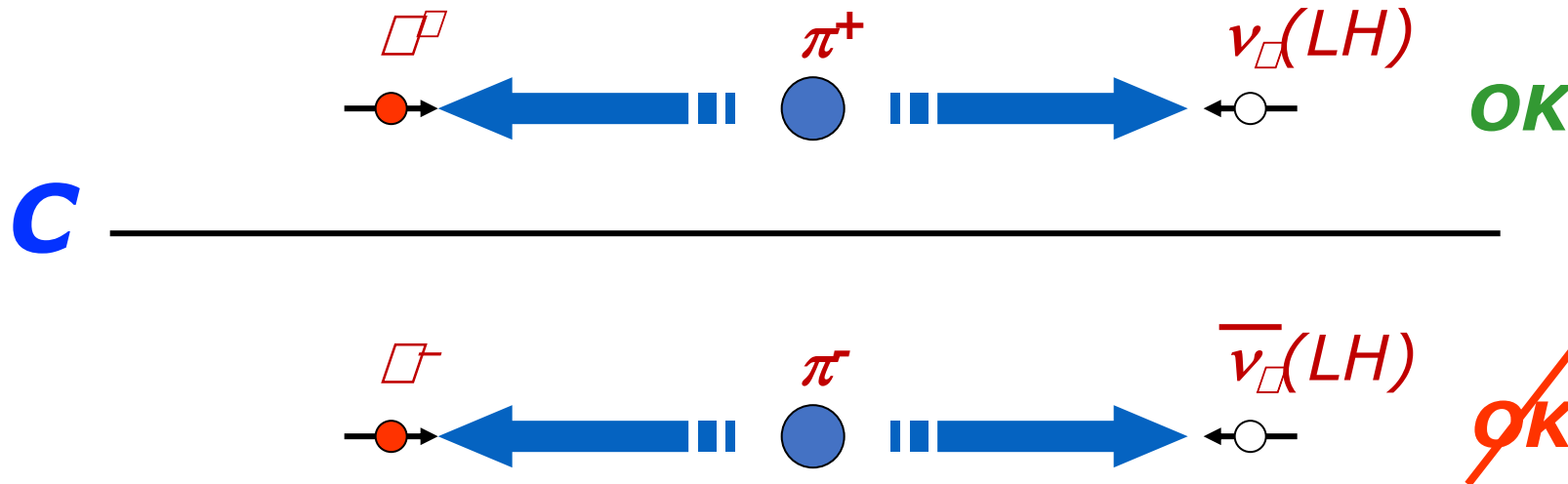

- C symmetry is similarly maximally broken by the weak interaction
 - Just like P

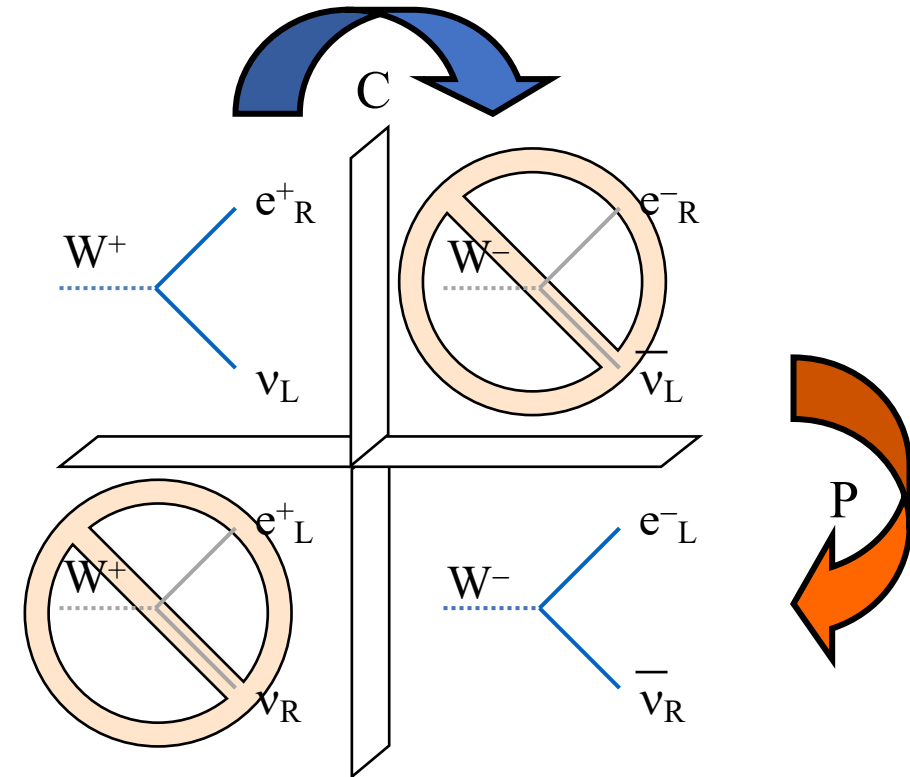
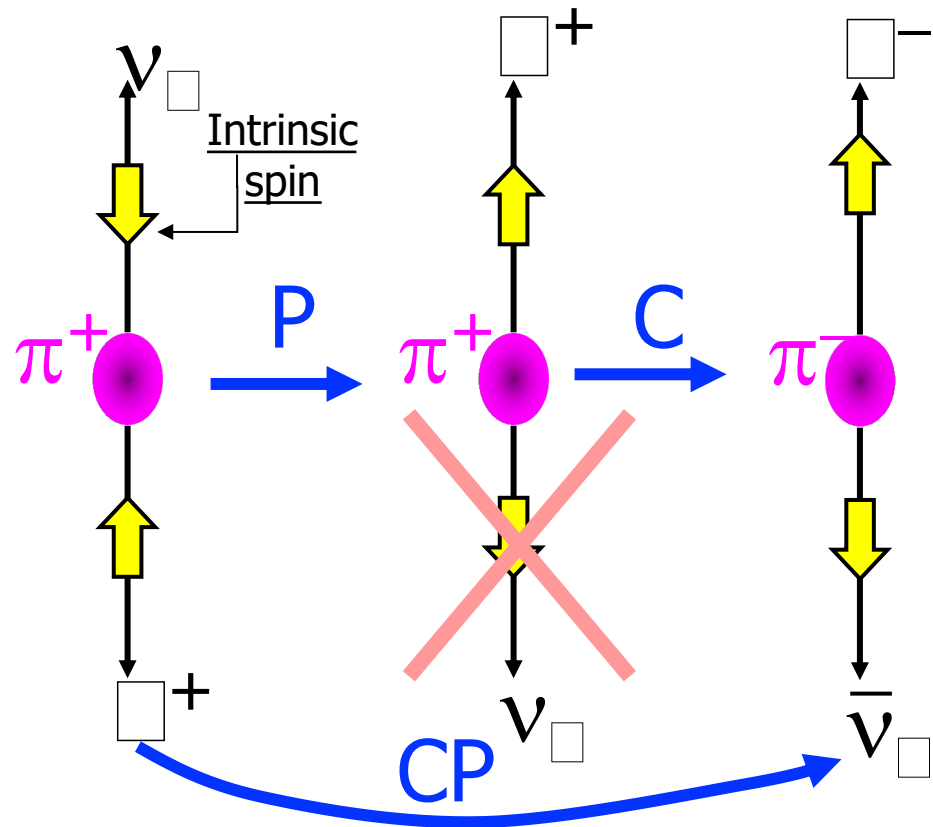

- CP symmetry is parity conjugation: $(x, y, z \rightarrow -x, -y, -z)$, followed by charge conjugation: $(\psi \rightarrow \bar{\psi})$

- CP symmetry *appears* to be preserved in the weak interaction
- But in 1964 looking at kaons...

Discovery of CP -Violation with K^0 decays

- Create a pure K_L beam (“wait” for K_S to decay)
- If CP is conserved, should **not** see $K_L \rightarrow \pi^+ \pi^-$

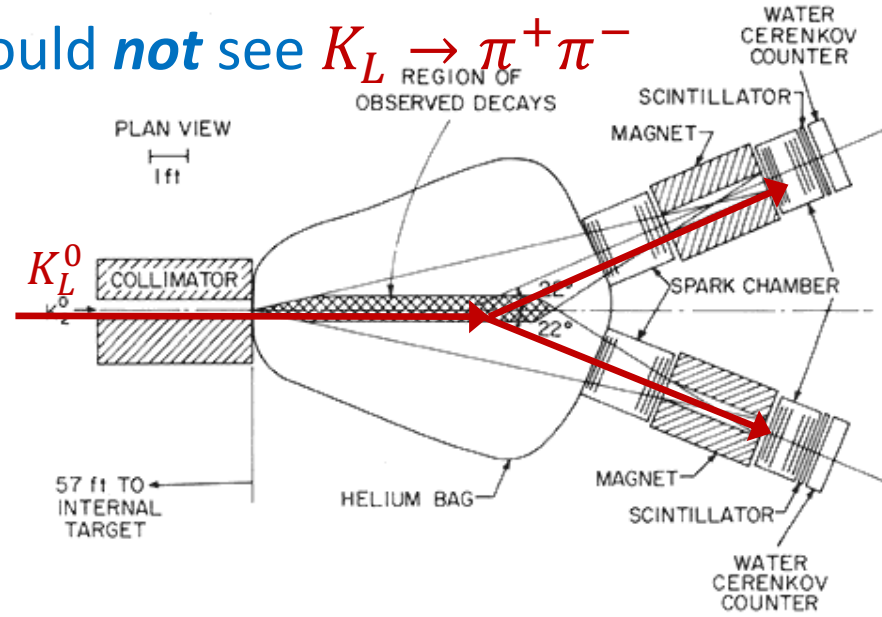
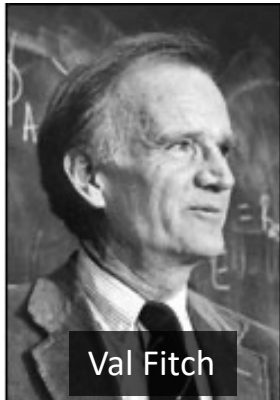

K_S : Short-lived is CP even:
 $K_1^0 \rightarrow \pi^+ \pi^-$ (fast)
 K_L : Long-lived is CP odd:
 $K_2^0 \rightarrow \pi^+ \pi^- \pi^0$ (slow)

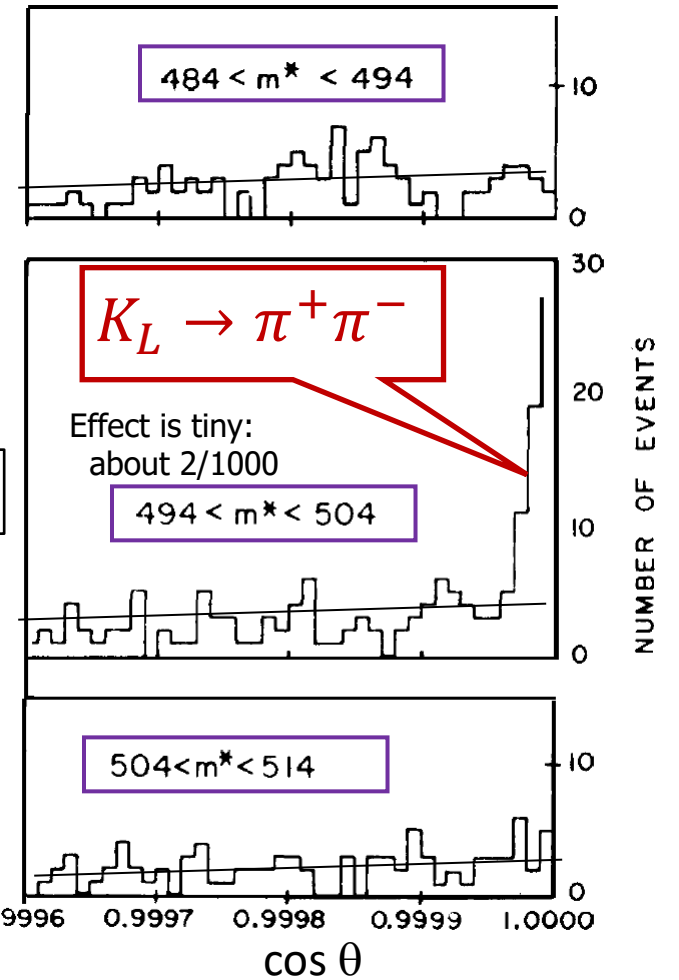

CP: $\overbrace{-1}^1$
 CP violating Signal: $K_L \rightarrow \pi^+ \pi^-$

CP: $\overbrace{-1}^{-1}$
 Background: $K_L \rightarrow \pi^+ \pi^- \pi^0$

π^0 remains undetected

$M_{K_S} = 498 \text{ MeV}$

mass, θ

0.9996 0.9997 0.9998 0.9999 1.0000

cos θ

Discovery of CP -Violation with K^0 decays

- Create a pure K_L beam ("wait" for K to decay)
- If CP is conserved,

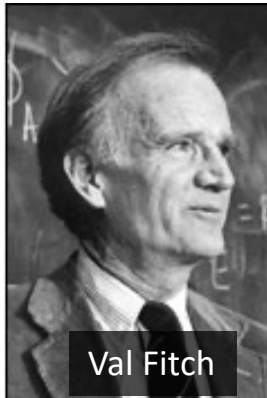
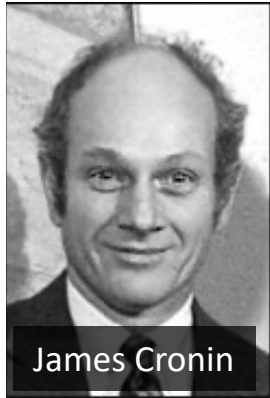

π^0 remains undetected

CP violating Signal: K

Background: K

K_S : Short-lived is CP even:

$$K_1^0 \rightarrow \pi^+ \pi^- \quad (\text{fast})$$

K_L : Long-lived is CP odd:

$$K_2^0 \rightarrow \pi^+ \pi^- \pi^0 \quad (\text{slow})$$

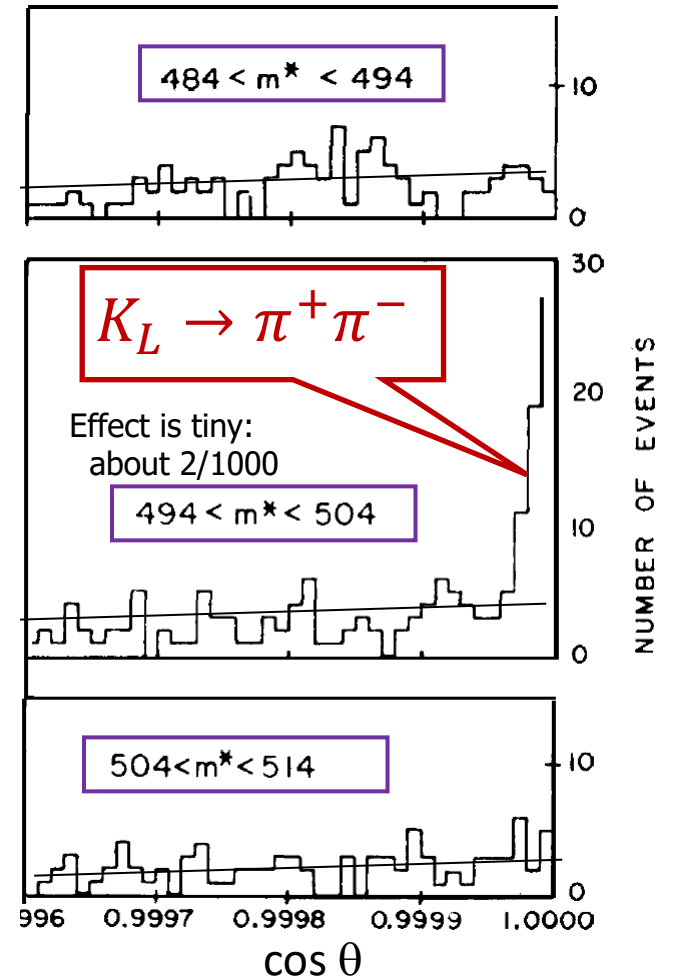

Measure $A = \frac{N^+ - N^-}{N^+ + N^-}$ with $N^+ = K^0 \rightarrow \pi^- e^+ \nu$ vs the K^0 decay time
 $N^- = \overline{K^0} \rightarrow \pi^+ e^- \bar{\nu}$

$$\frac{N^+ - N^-}{N^+ + N^-} =$$

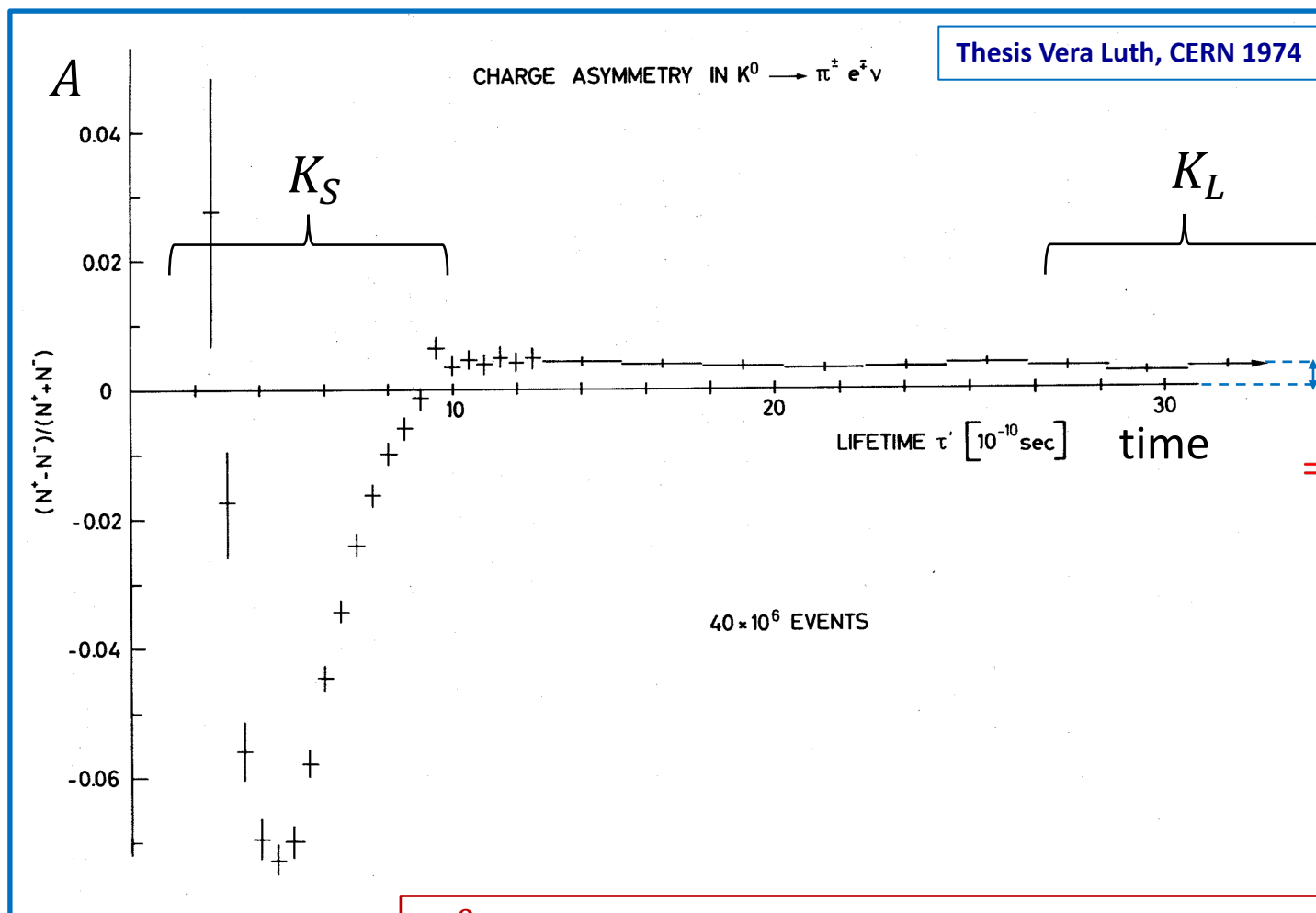

$$4\Re(\epsilon)$$

$$= \left| \frac{(1 + \epsilon)}{(1 - \epsilon)} \right|^2$$

CP violation in meson mixing.

K_L^0 decays with long lifetime decay slightly more to e^+ than to e^-

Alternative: Charge Asymmetry in K^0 decays

Measure $A = \frac{N^+ - N^-}{N^+ + N^-}$ with $N^+ = K^0 \rightarrow \pi^- e^+ \nu$ vs the K^0 decay time
 $N^- = \bar{K}^0 \rightarrow \pi^+ e^- \bar{\nu}$

$$\frac{N^+ - N^-}{N^+ + N^-} =$$

Two CP states:

$$|K_1\rangle = \frac{1}{\sqrt{2}} [|K^0\rangle - |\bar{K}^0\rangle]$$

$$|K_2\rangle = \frac{1}{\sqrt{2}} [|K^0\rangle + |\bar{K}^0\rangle]$$

Two particles:

$$|K_S\rangle \simeq [|K_1\rangle + \varepsilon |K_2\rangle]$$

$$|K_L\rangle \simeq [|K_2\rangle + \varepsilon |K_1\rangle]$$

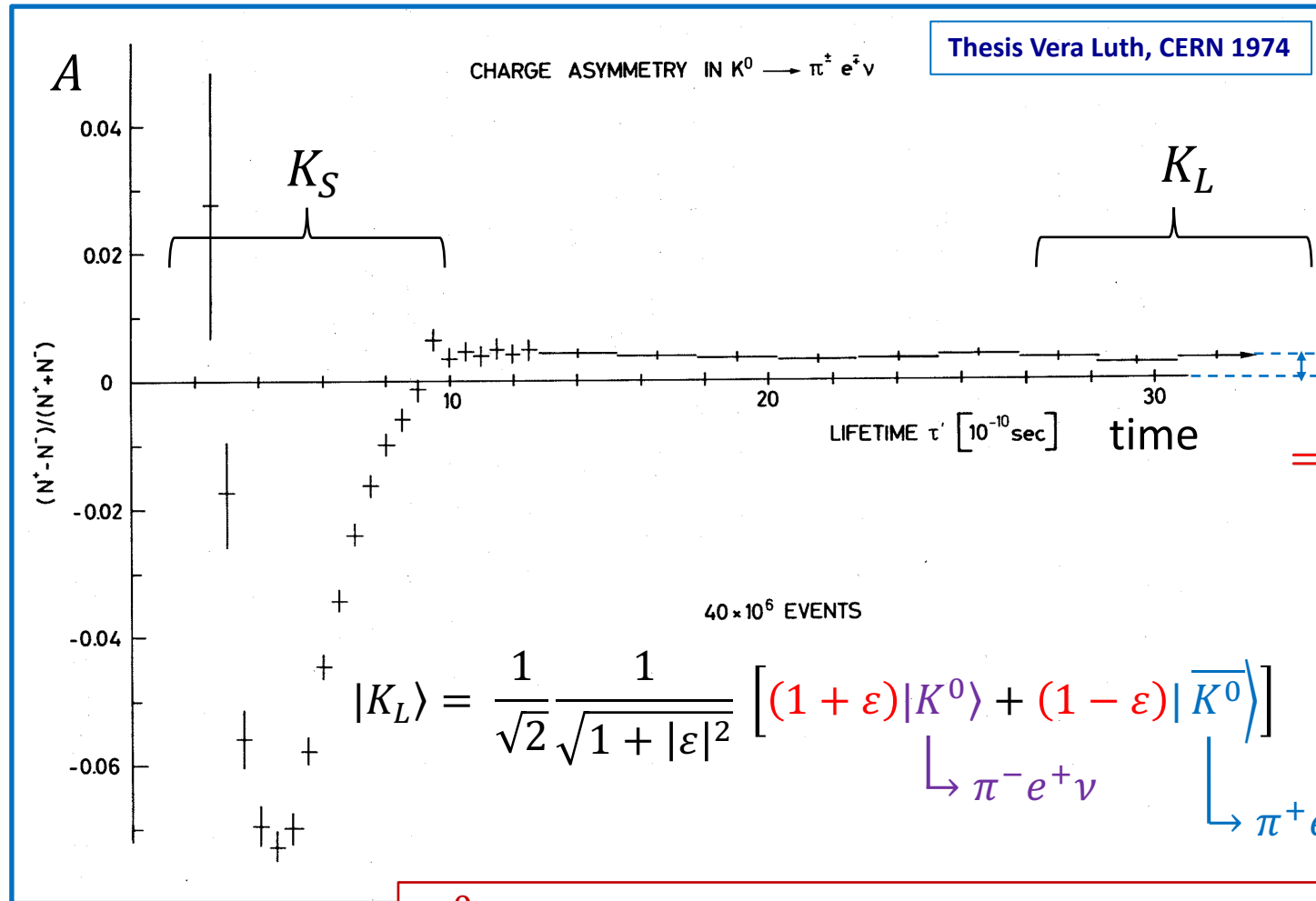

Kaon has $J^P = 0^-$:

$$P|K^0\rangle = -|\bar{K}^0\rangle$$

$$P|\bar{K}^0\rangle = -|K^0\rangle$$

$$4\Re(\varepsilon)$$

$$= \left| \frac{(1 + \varepsilon)}{(1 - \varepsilon)} \right|^2$$

CP violation in meson mixing.

K_L^0 decays with long lifetime decay slightly more to e^+ than to e^-

Are they made of matter or anti-matter?



Contact with Aliens !

Are they made of matter or anti-matter?

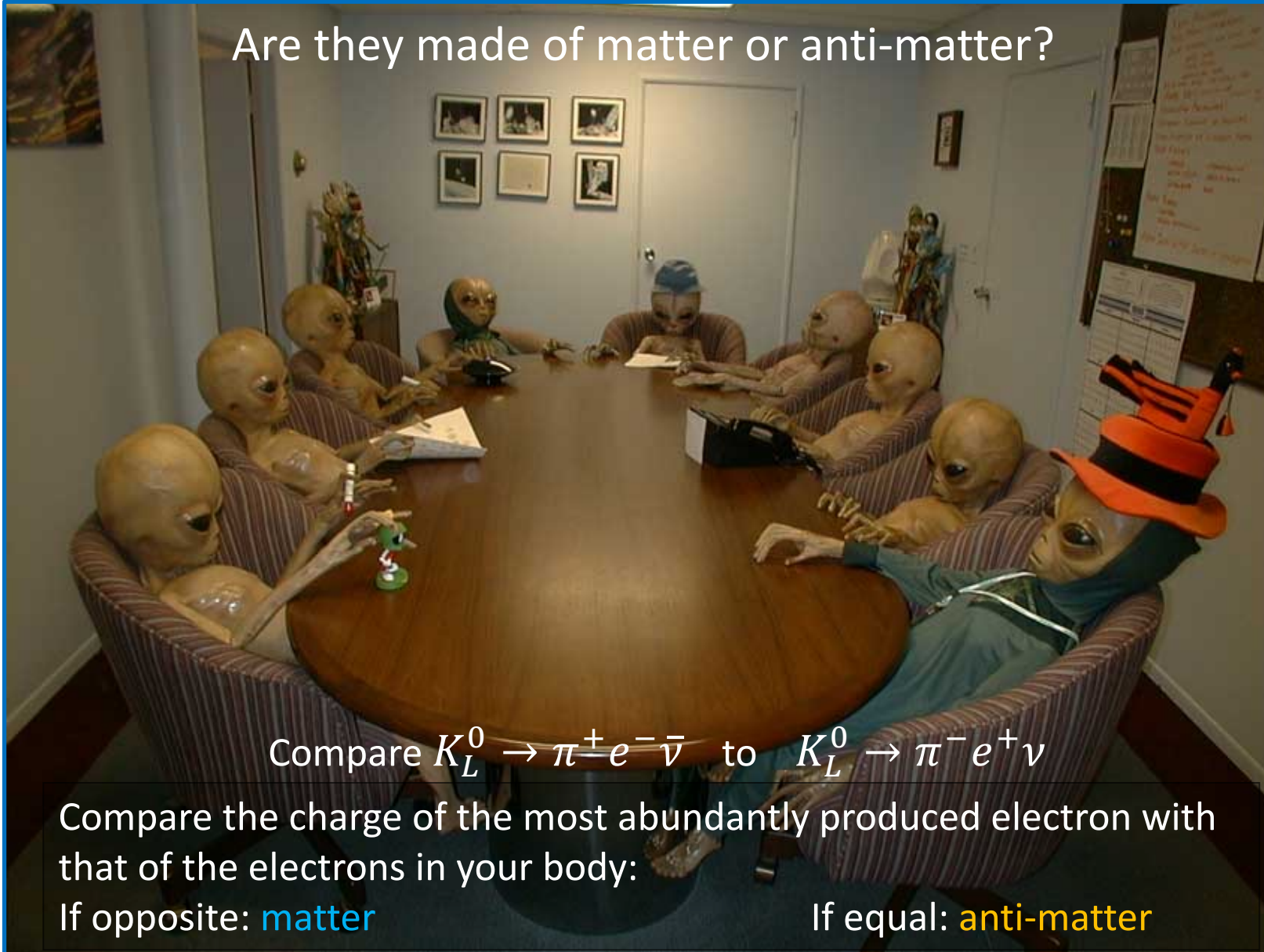

Compare $K_L^0 \rightarrow \pi^+ e^- \bar{\nu}$ to $K_L^0 \rightarrow \pi^- e^+ \nu$

Compare the charge of the most abundantly produced electron with that of the electrons in your body:

If opposite: **matter**

If equal: **anti-matter**



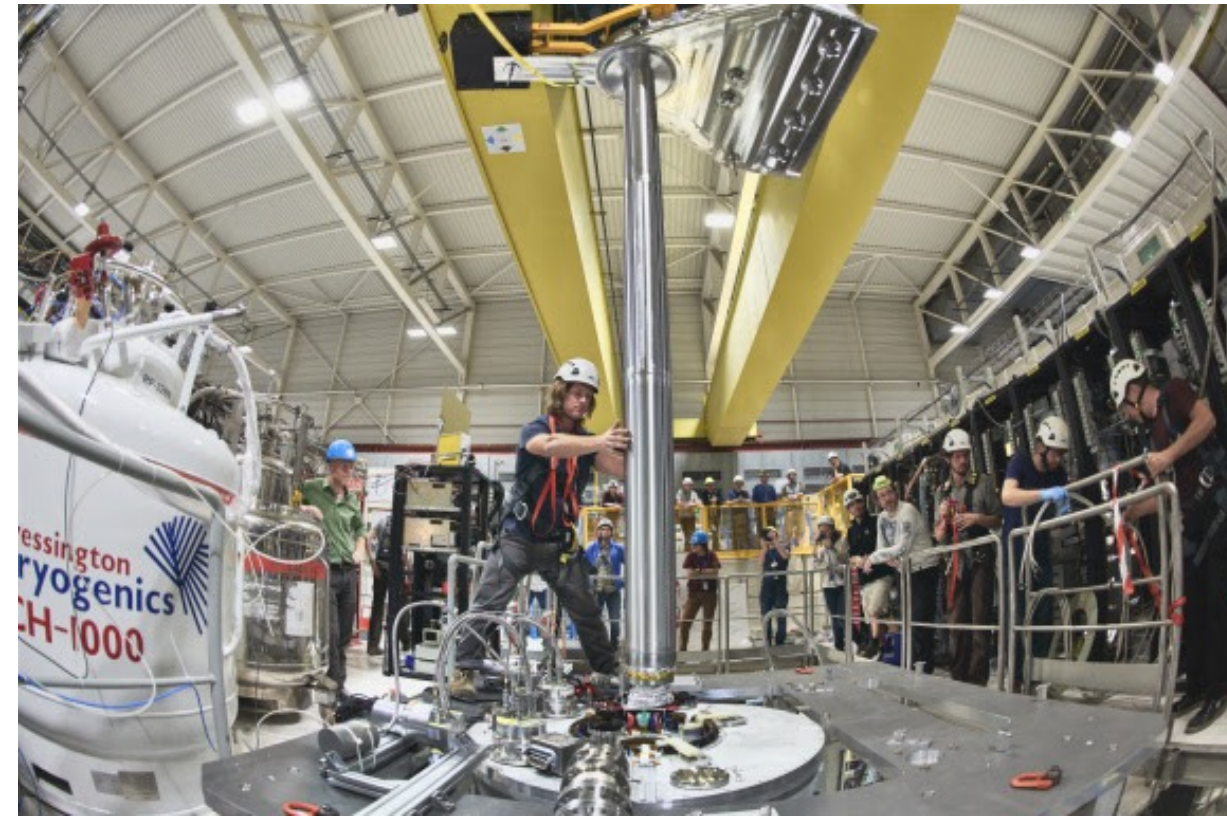
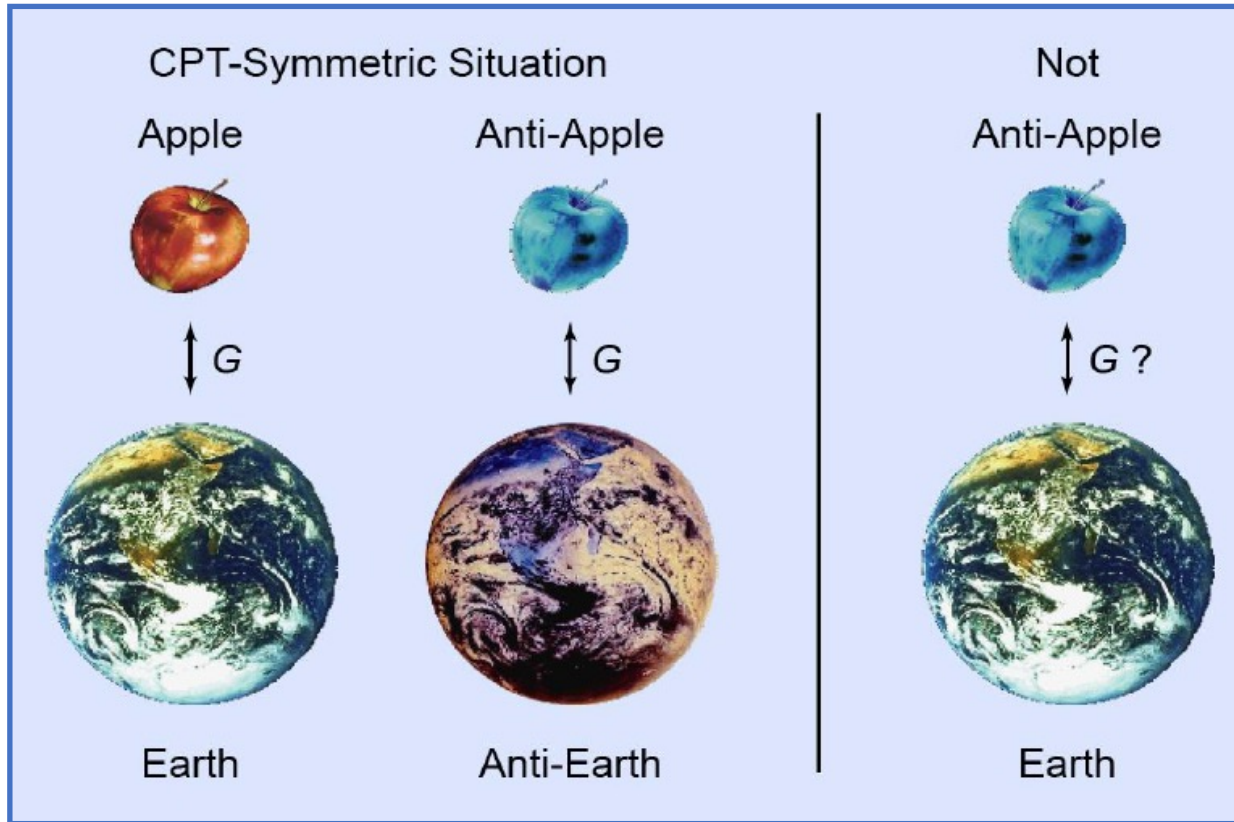

- **News on 27 Sept 2023:**

- Several thousands of antimatter hydrogen atoms were dropped in the gravitational field
- Antimatter falls “down” to earth in the same way as matter does

See: [CERN news](#)



CPT symmetry implies that an antiparticle is *identical* to a particle travelling backwards in time.

Contents:

1. Discrete Symmetries C, P and CP
2. CP violation in the Weak Force
3. How can we measure it?
4. The matter – antimatter asymmetry

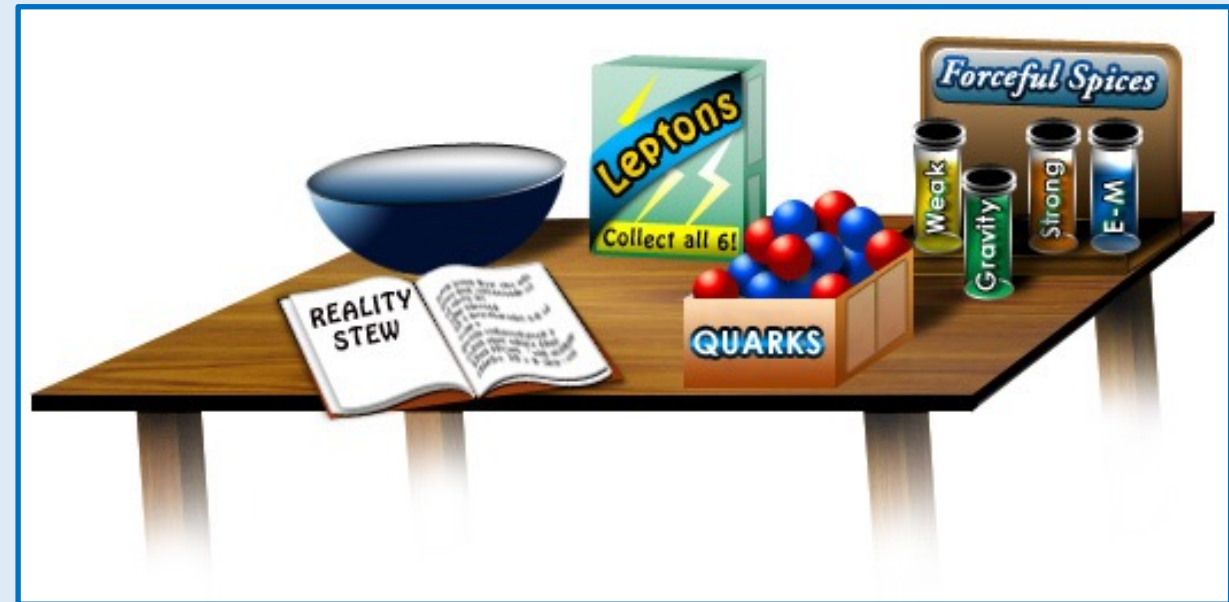

Weak interaction in three Flavour Generations



- Weak Interaction is 100% parity violating.
 - Wolfgang Pauli: “I cannot believe God is a weak left-hander.”

- Implement an $SU(2)_L$ symmetry for *massless* particles:

$$\mathcal{L}_W = \frac{g}{\sqrt{2}} u'_L \gamma_\mu W^\mu d'_L \quad \text{x3 !}$$

Note:

$$\psi_L = \frac{1}{2}(1 - \gamma^5)\psi$$

- Flavour universality: *identical interactions* in three generations.
 - In fact: *how to distinguish a massless d' quark from s' quark?*

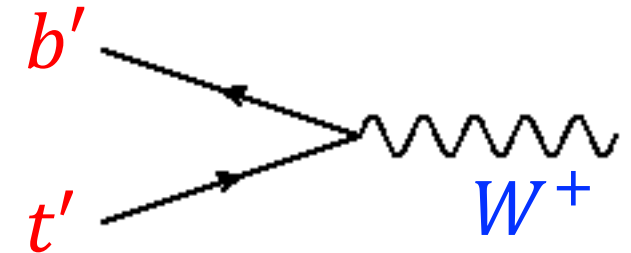
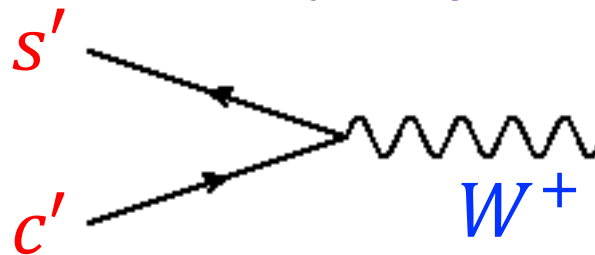
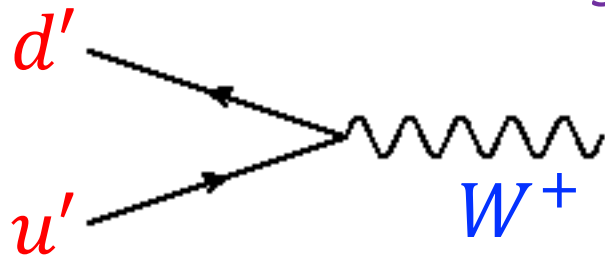

- There is *no CP violation* in these massless interactions
 - What happens when particles acquire mass after symmetry breaking?

- After symmetry breaking the massless flavour states mix into mass states:

$$u_i = (V^u)_{ij} u'_j \quad \text{and} \quad d_i = (V^d)_{ij} d'_j \quad V_{CKM} = V^{u\dagger} V^d$$

$$\mathcal{L}_W = \frac{g}{\sqrt{2}} u'_L \gamma_\mu W^\mu d'_L \quad \longrightarrow \quad \mathcal{L}_W = \frac{g}{\sqrt{2}} V_{CKM} u_L \gamma_\mu W^\mu d_L$$

d	$\mathcal{L}_W = \frac{g}{\sqrt{2}} u'_L \gamma_\mu W^\mu d'_L$	s	$\mathcal{L}_W = \frac{g}{\sqrt{2}} u'_L \gamma_\mu W^\mu d'_L$	b	$\mathcal{L}_W = \frac{g}{\sqrt{2}} u'_L \gamma_\mu W^\mu d'_L$
u	W^+	u	W^+	u	W^+
d	$\mathcal{L}_W = \frac{g}{\sqrt{2}} u'_L \gamma_\mu W^\mu d'_L$	s	$\mathcal{L}_W = \frac{g}{\sqrt{2}} u'_L \gamma_\mu W^\mu d'_L$	b	$\mathcal{L}_W = \frac{g}{\sqrt{2}} u'_L \gamma_\mu W^\mu d'_L$
c	W^+	c	W^+	c	W^+
d	$\mathcal{L}_W = \frac{g}{\sqrt{2}} u'_L \gamma_\mu W^\mu d'_L$	s	$\mathcal{L}_W = \frac{g}{\sqrt{2}} u'_L \gamma_\mu W^\mu d'_L$	b	$\mathcal{L}_W = \frac{g}{\sqrt{2}} u'_L \gamma_\mu W^\mu d'_L$
t	W^+	t	W^+	t	W^+

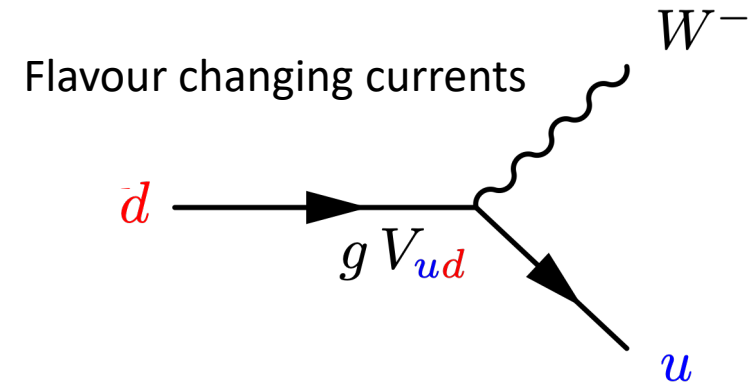
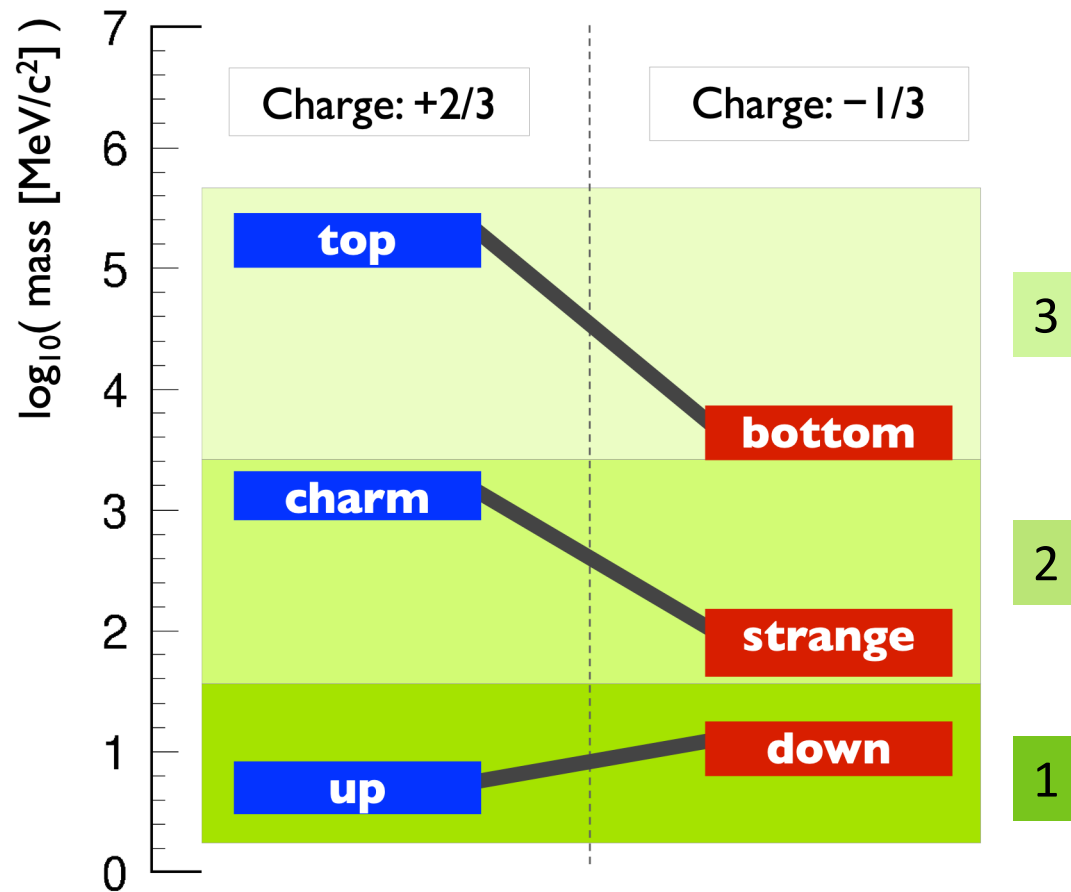

$$V_{\text{CKM}} = \begin{pmatrix} V_{ud} & & \\ & V_{cs} & \\ & & V_{tb} \end{pmatrix}$$

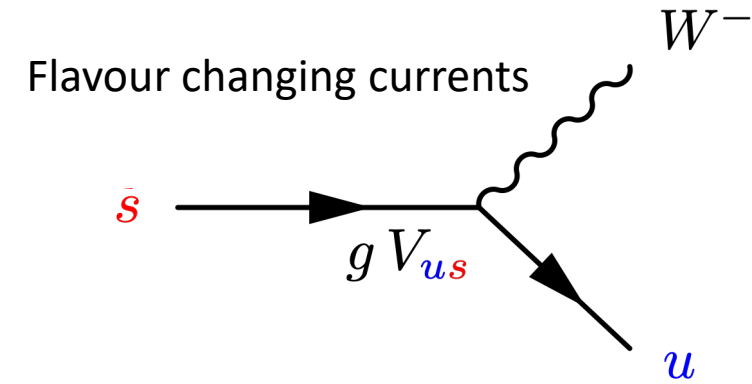
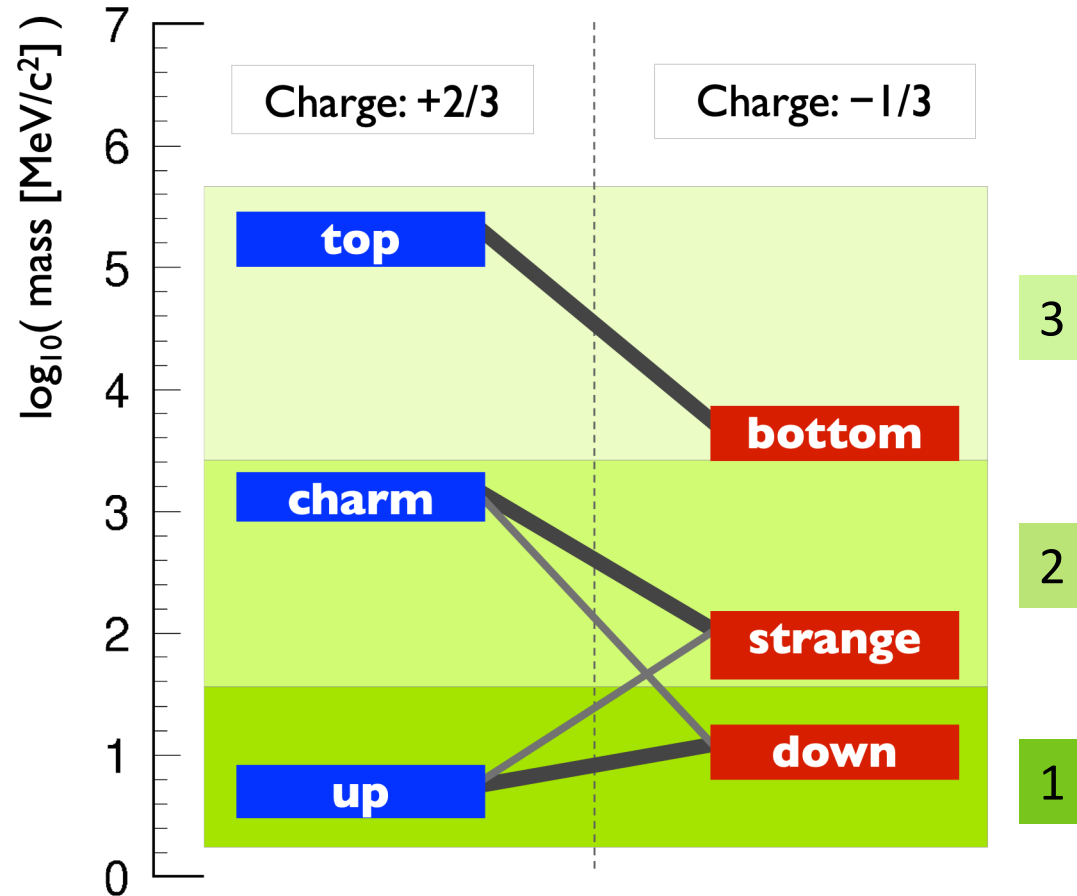

$$V_{\text{CKM}} = \begin{pmatrix} V_{ud} & V_{us} & \\ V_{cd} & V_{cs} & \\ & & V_{tb} \end{pmatrix}$$

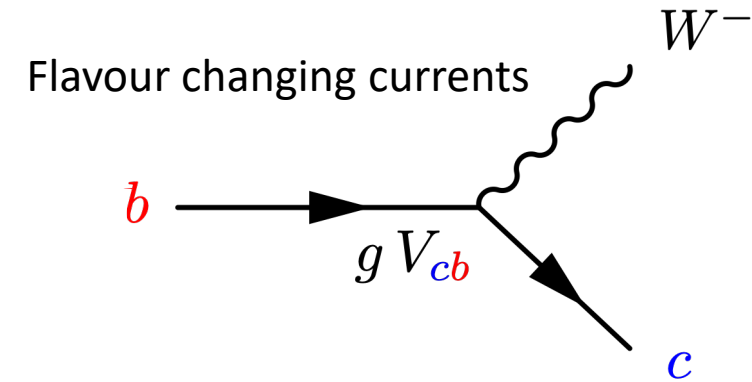
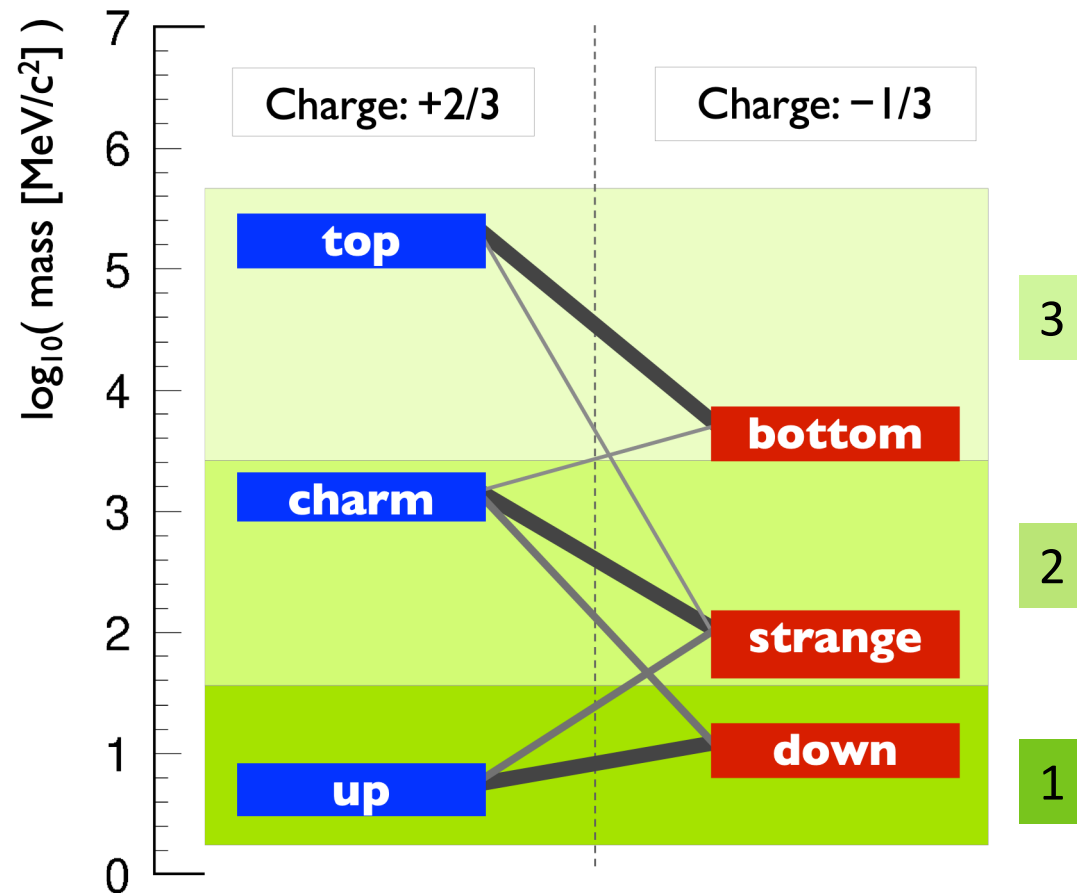

$$V_{\text{CKM}} = \begin{pmatrix} V_{ud} & V_{us} & V_{ub} \\ V_{cd} & V_{cs} & V_{cb} \\ V_{td} & V_{ts} & V_{tb} \end{pmatrix}$$

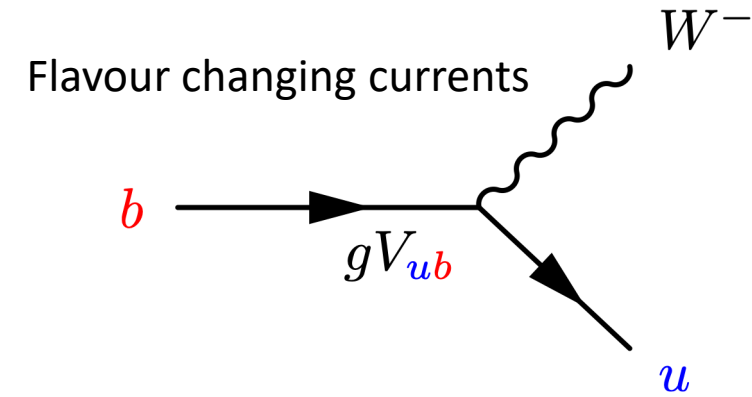
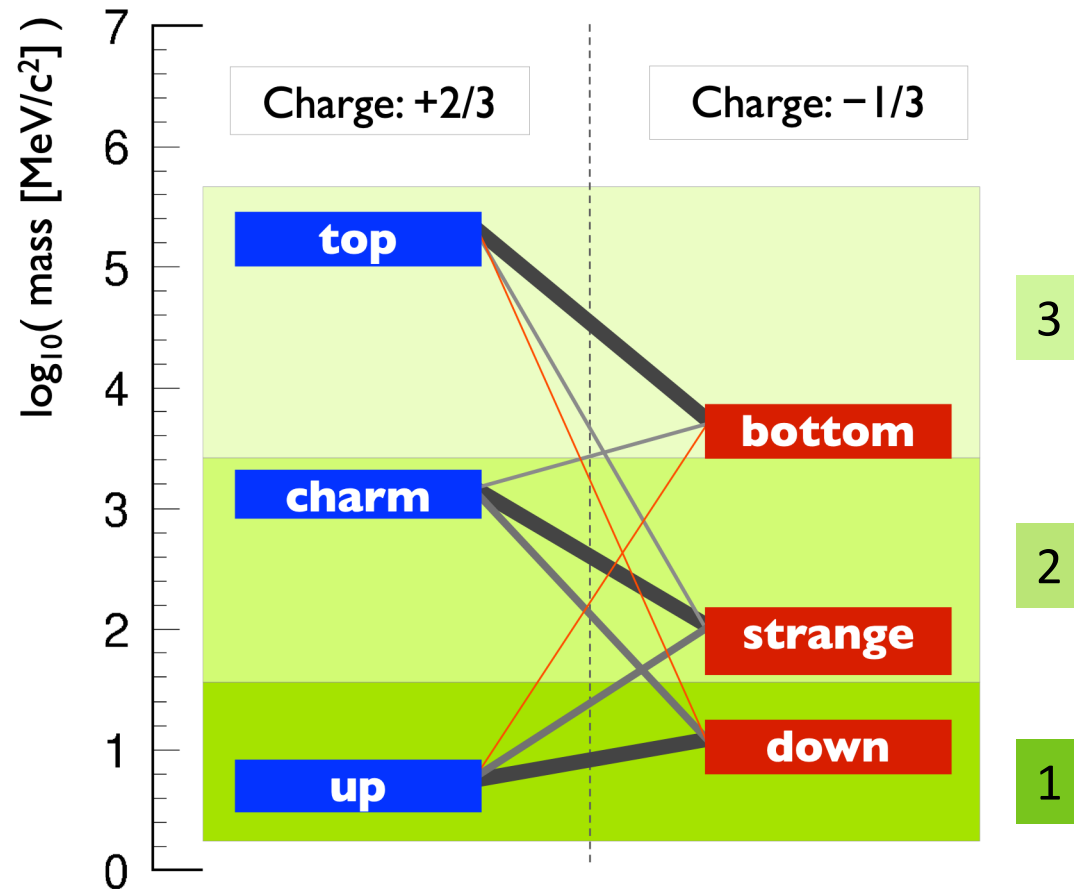

$$V_{\text{CKM}} = \begin{pmatrix} V_{ud} & V_{us} & V_{ub} \\ V_{cd} & V_{cs} & V_{cb} \\ V_{td} & V_{ts} & V_{tb} \end{pmatrix}$$

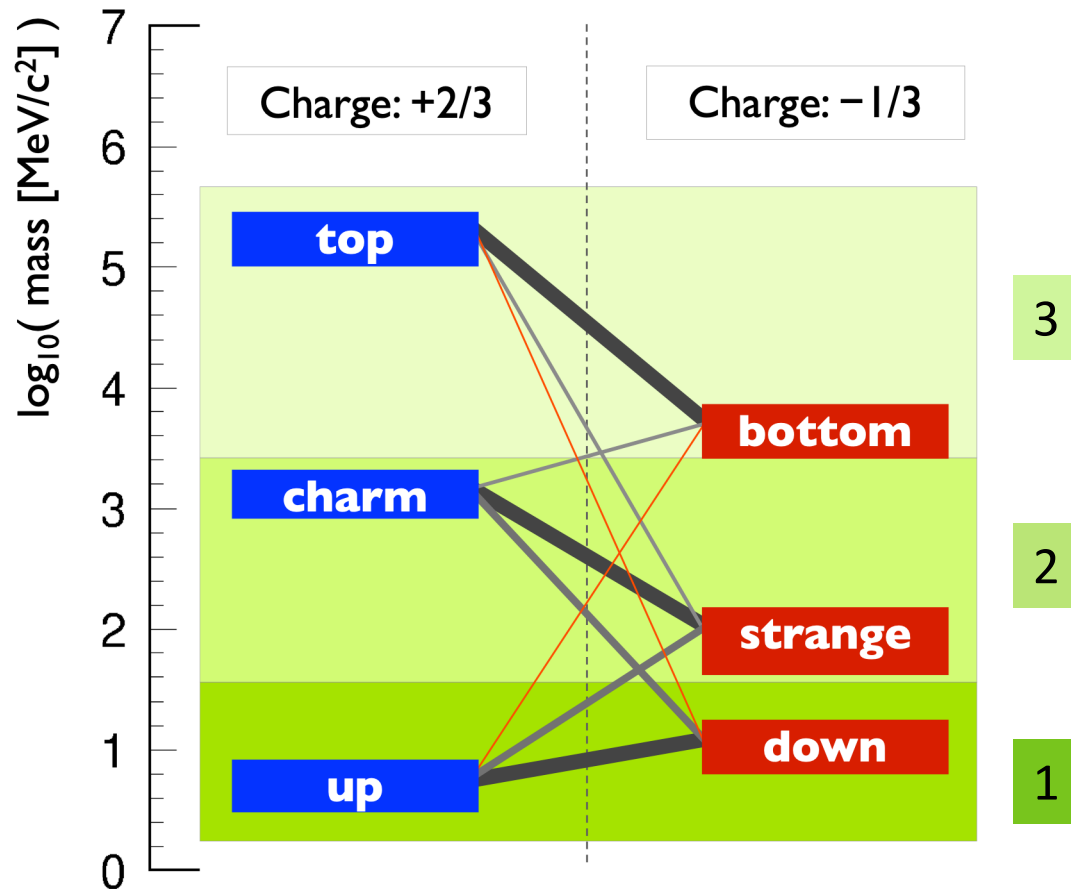

- Particle and antiparticle interactions have complex conjugated coupling constants
- The complex coupling is a requirement to observe CP violation

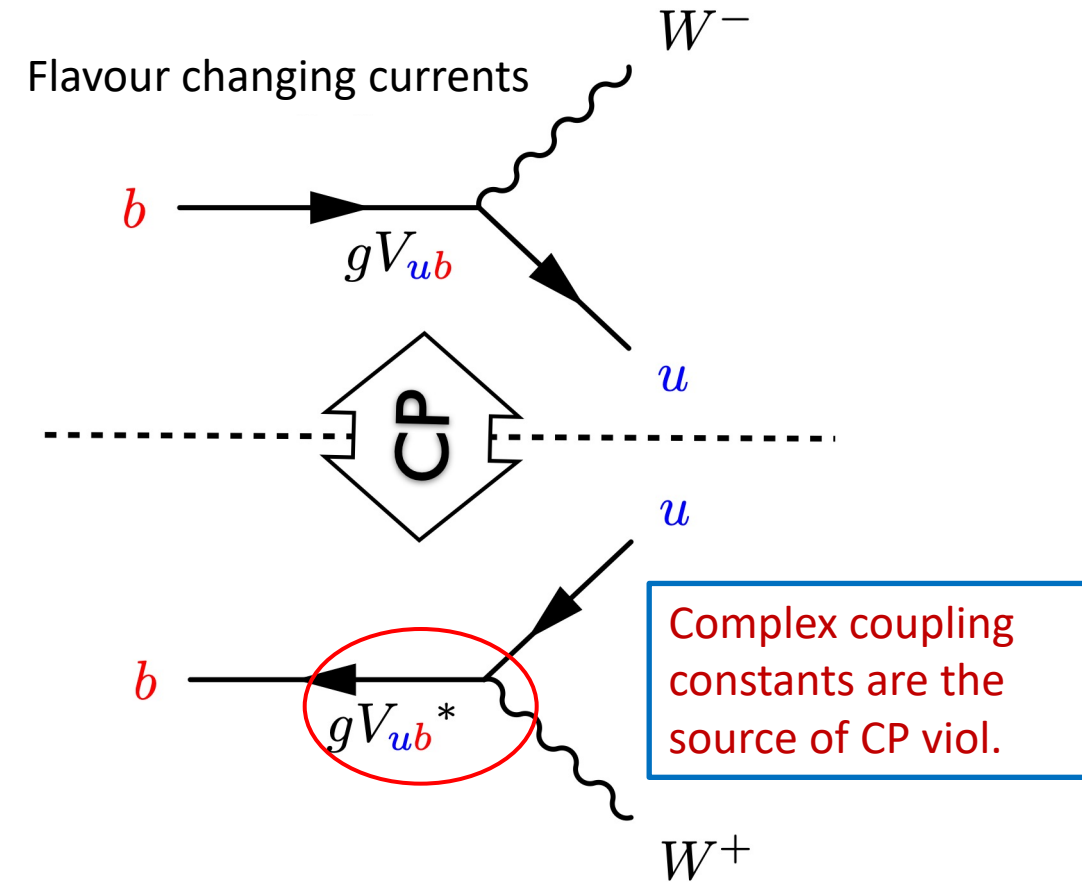

$$V_{\text{CKM}} = \begin{pmatrix} V_{ud} & V_{us} & V_{ub} \\ V_{cd} & V_{cs} & V_{cb} \\ V_{td} & V_{ts} & V_{tb} \end{pmatrix}$$

Contents:

1. Discrete Symmetries C, P and CP
2. CP violation in the weak force
3. How can we measure it?
4. The matter – antimatter asymmetry

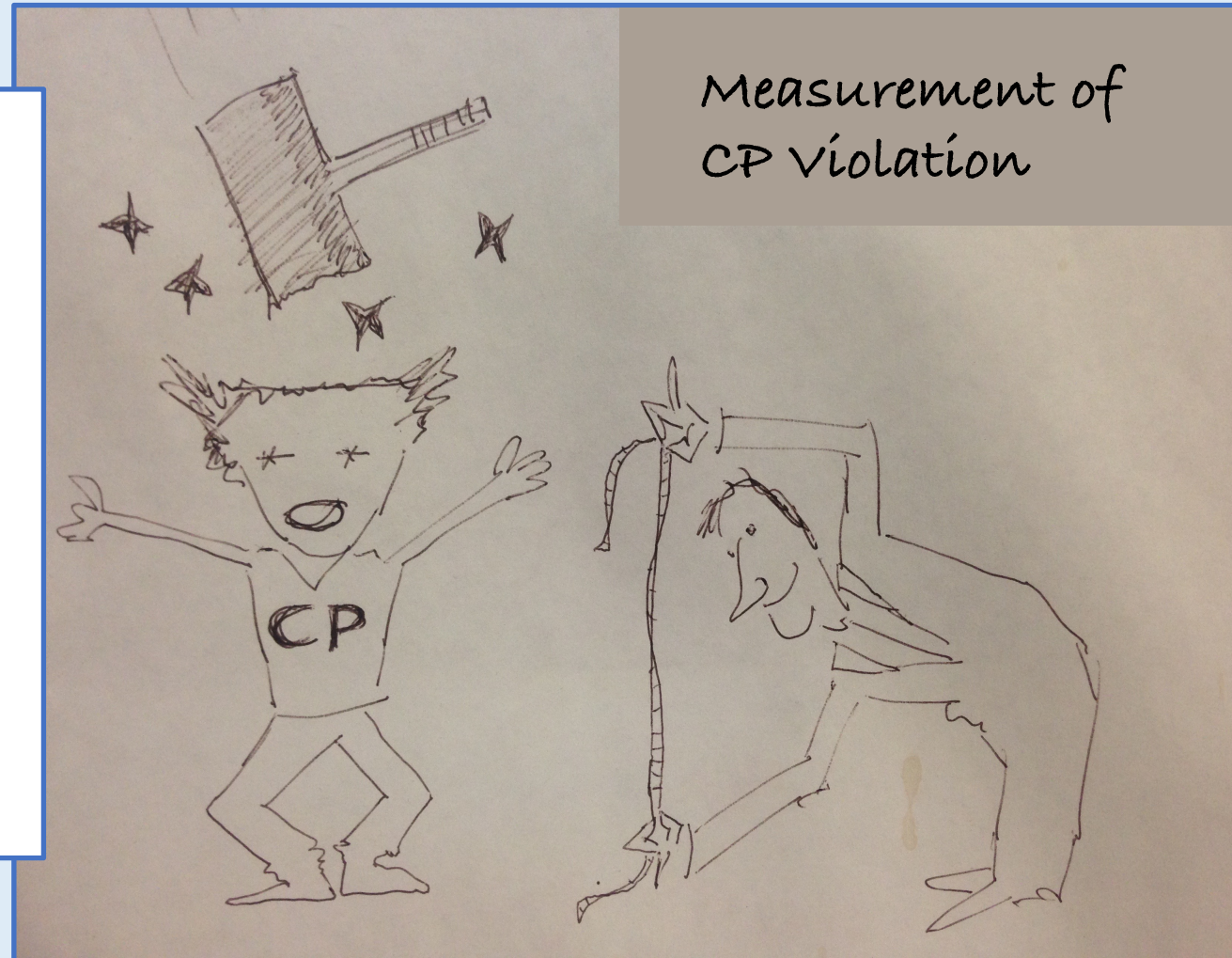

- Consider a “matter process”:
 $B_s^0 \rightarrow \pi^+ K^-$

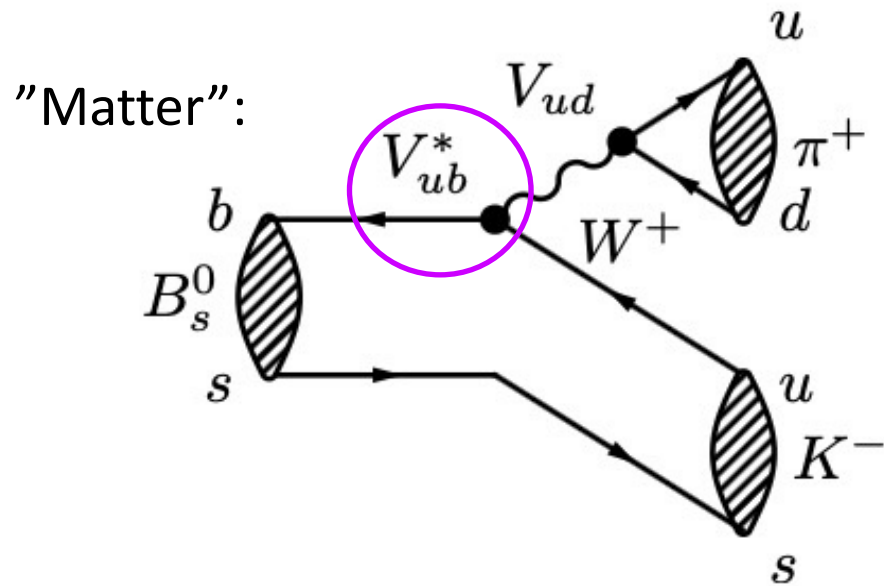

$$Prob = |A|^2 = |Ae^{i\phi}|^2 = A^2 e^{i\phi} e^{-i\phi}$$

- And the “antimatter process”:
 $\bar{B}_s^0 \rightarrow \pi^- K^+$

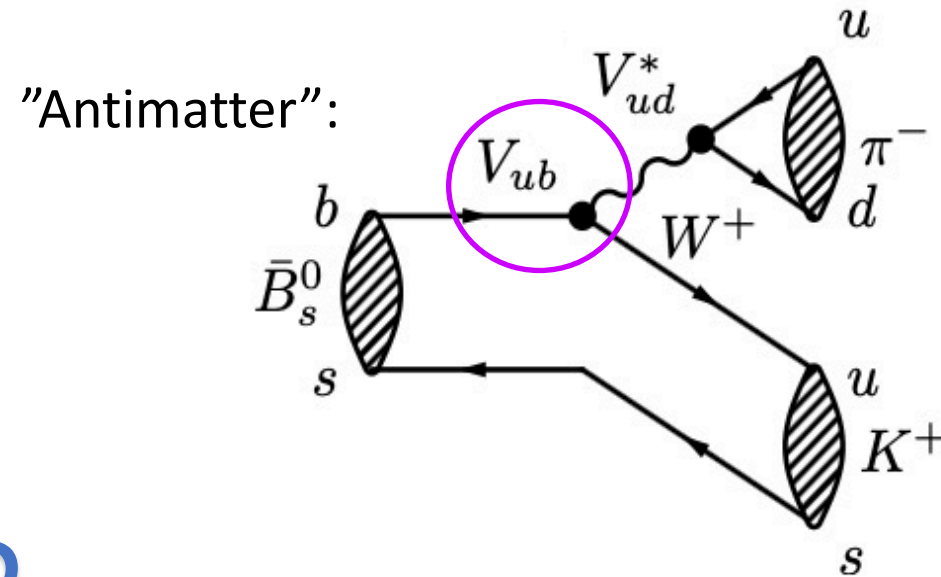

$$Prob = |\bar{A}|^2 = |Ae^{-i\phi}|^2 = A^2 e^{-i\phi} e^{i\phi}$$

?

- Even with complex couplings the decay rates are expected the same?!

"Matter":

$$A = A_1 + A_2 e^{i\phi} e^{i\delta}$$

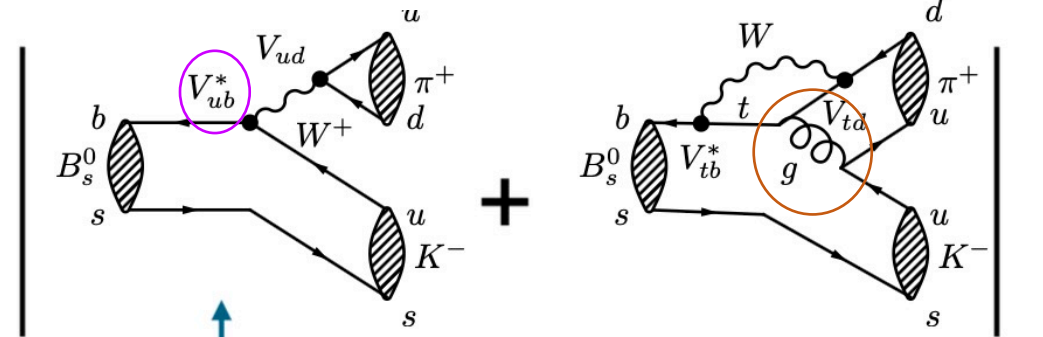

CP operation

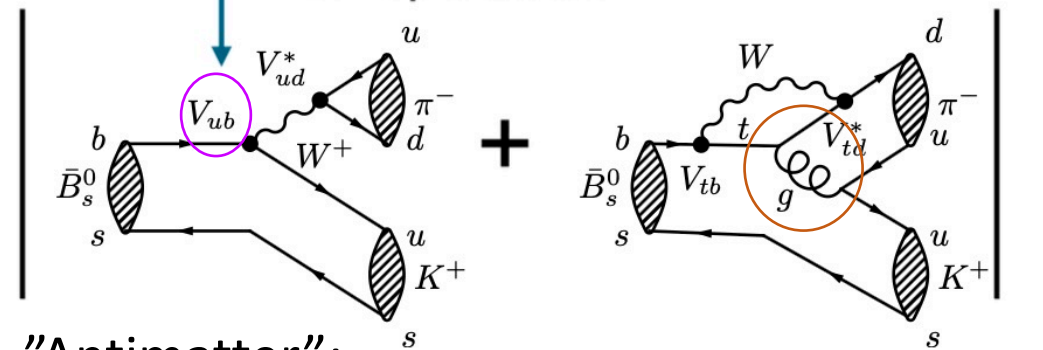

"Antimatter":

$$\bar{A} = A_1 + A_2 e^{-i\phi} e^{i\delta}$$

$$|A|^2 = |A_1|^2 + |A_2|^2 + A_1 A_2 (e^{i\phi} e^{i\delta} + e^{-i\phi} e^{-i\delta})$$



$$|\bar{A}|^2 = |A_1|^2 + |A_2|^2 + A_1 A_2 (e^{-i\phi} e^{i\delta} + e^{i\phi} e^{-i\delta})$$

CP Asymmetry: $|A|^2 - |\bar{A}|^2 = 4 A_1 A_2 \sin \phi \sin \delta \neq 0$

CP violation!

"Matter":

$$A = A_1 + A_2 e^{i\phi} e^{i\delta}$$

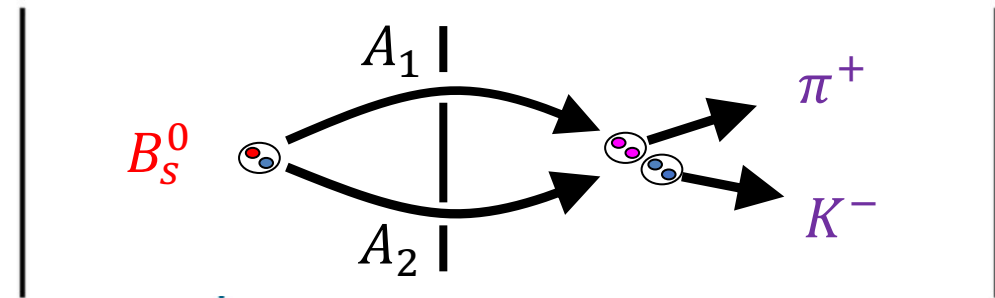

$$|A|^2 = |A_1|^2 + |A_2|^2 + 2 A_1 A_2 (e^{i\phi} e^{i\delta} + e^{-i\phi} e^{-i\delta})$$

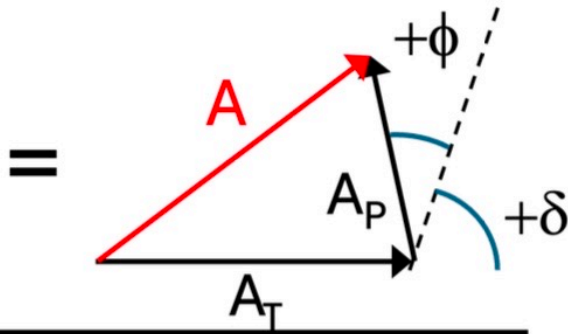

CP operation

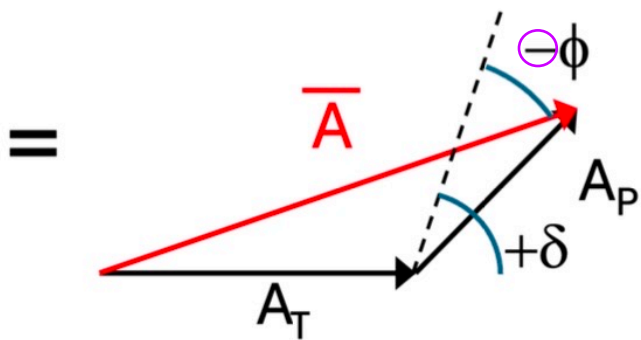
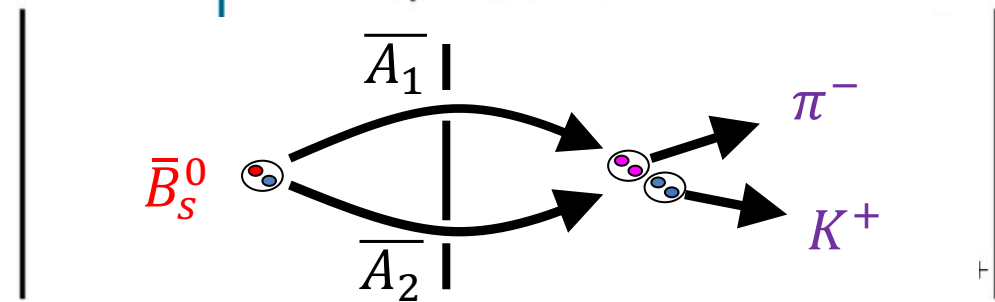

"Antimatter":

$$\bar{A} = A_1 + A_2 e^{-i\phi} e^{i\delta}$$

$$|\bar{A}|^2 = |A_1|^2 + |A_2|^2 + 2 A_1 A_2 (e^{-i\phi} e^{i\delta} + e^{i\phi} e^{-i\delta})$$

CP Asymmetry: $|A|^2 - |\bar{A}|^2 = 4 A_1 A_2 \sin \phi \sin \delta \neq 0$

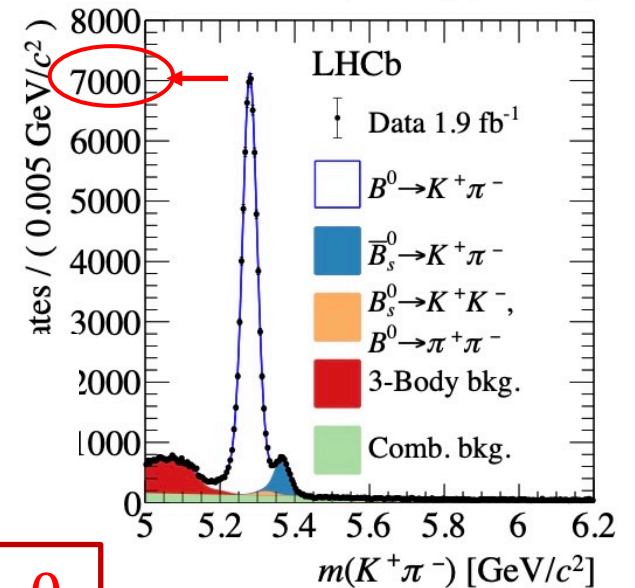
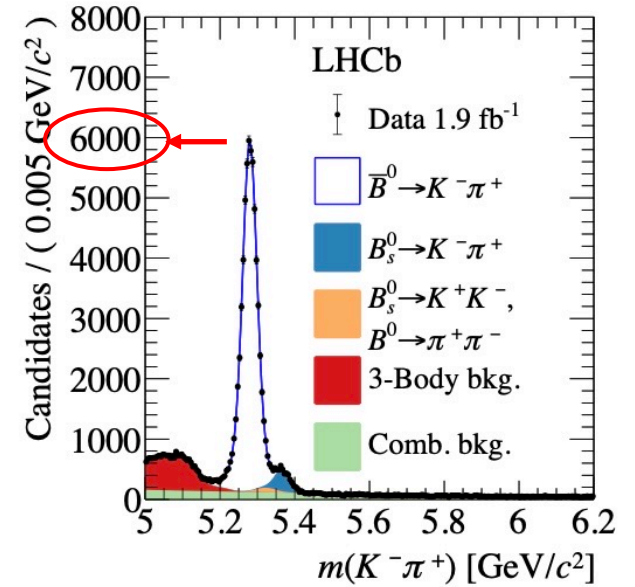

CP violation!

- Feynman: “In the end all quantum phenomena are manifestations of the double slit experiment.”

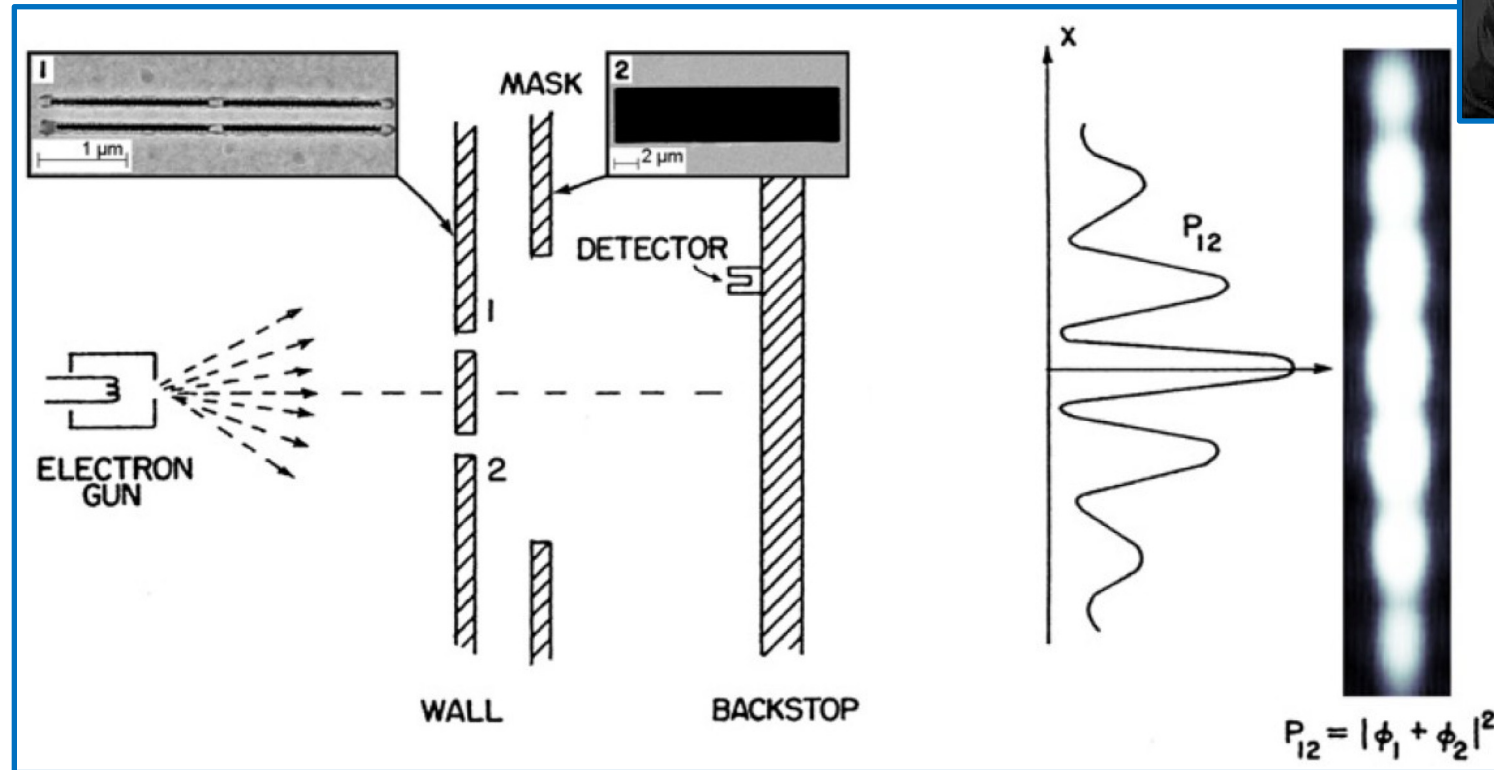
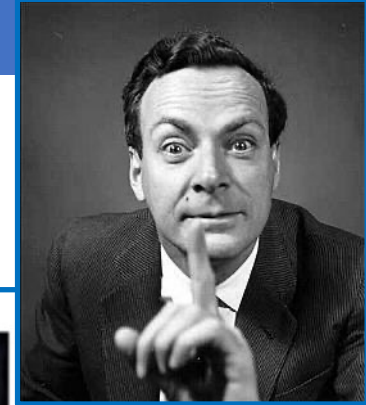

- Thought: Assuming CPT symmetry, CP violation implies a quantum arrow of time*
 - Quantum interference \leftrightarrow arrow of time?*

Contents:

1. Discrete Symmetries C, P and CP
2. CP violation in the weak force
3. How can we measure it?
4. The matter – antimatter asymmetry

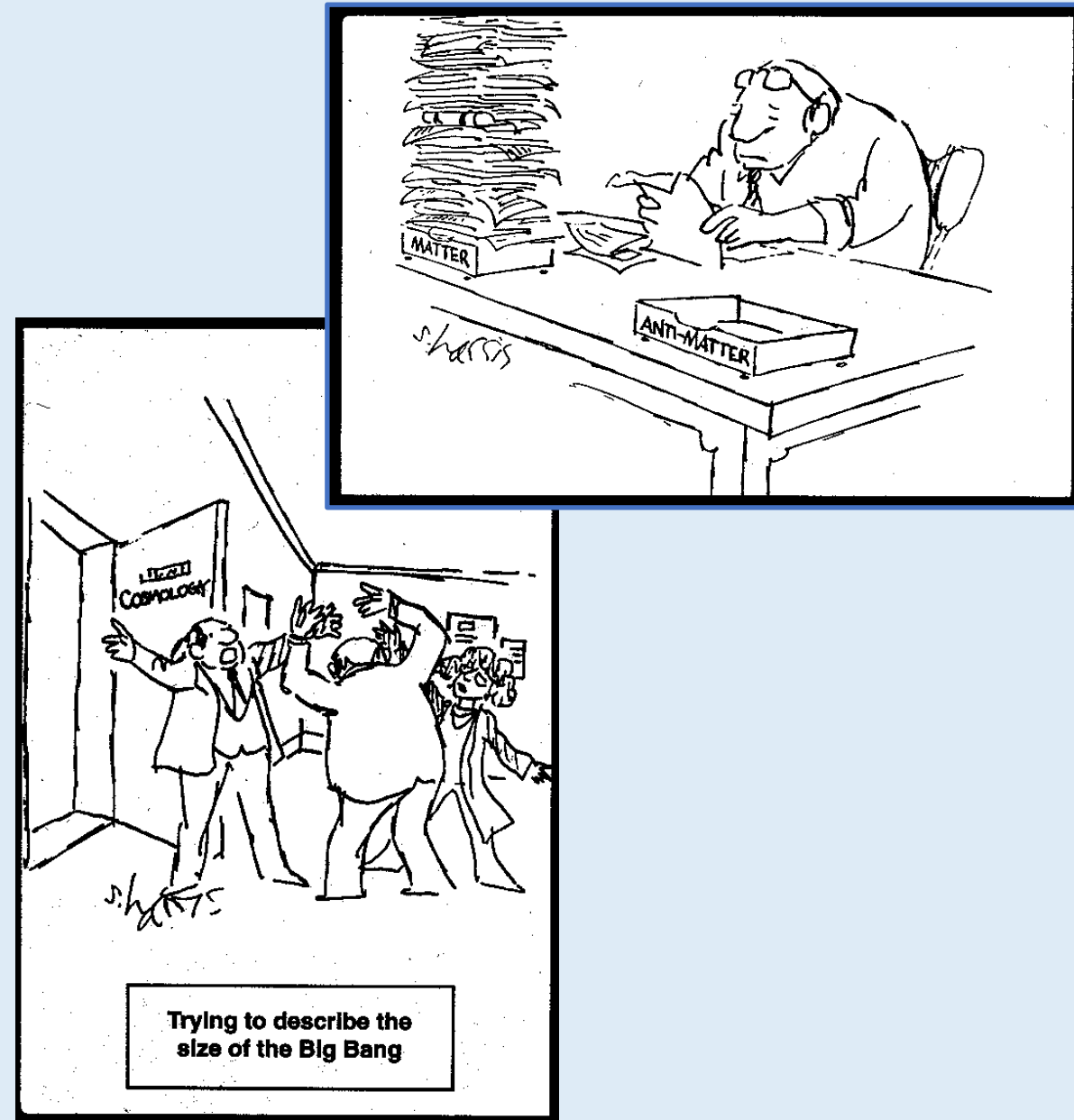

- Sacharov Conditions
 - ✓ All present in S.M.

1. Baryon asymmetry

✓ Baryon Number Violation

Adler-Bell-Jackiw

't Hooft, PRL 37 (1976) 8

Axial Anomaly: $\partial_\mu j^{\mu 5} \neq 0$

Quantum anomaly

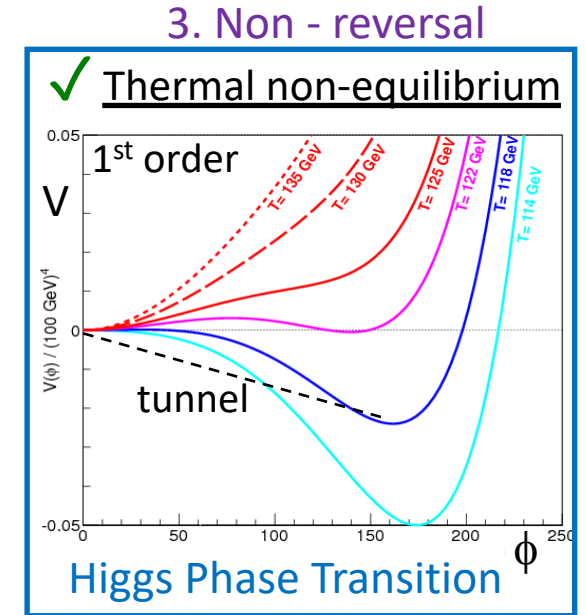
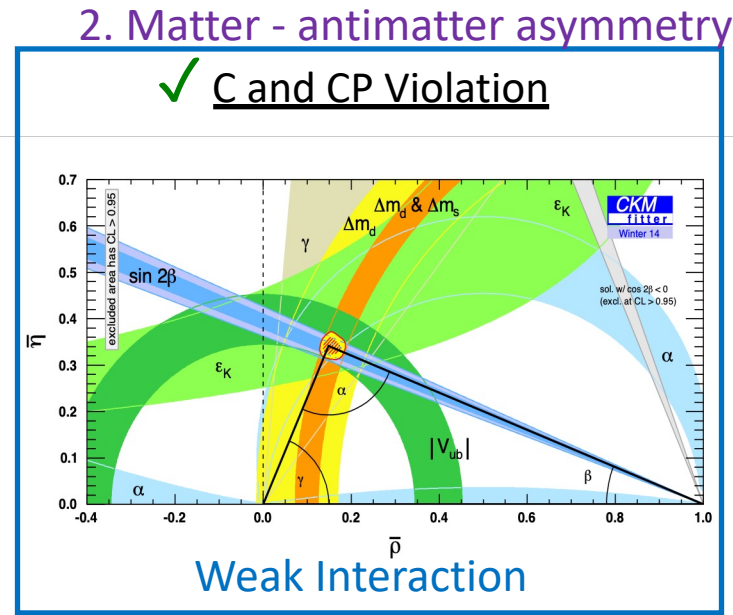

- Baryogenesis from Higgs symmetry breaking?

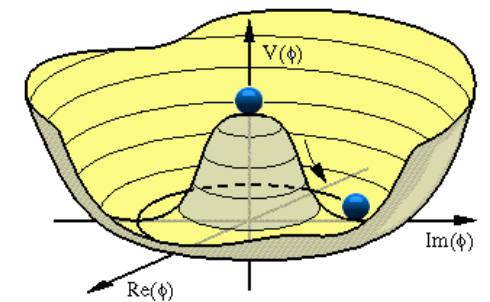
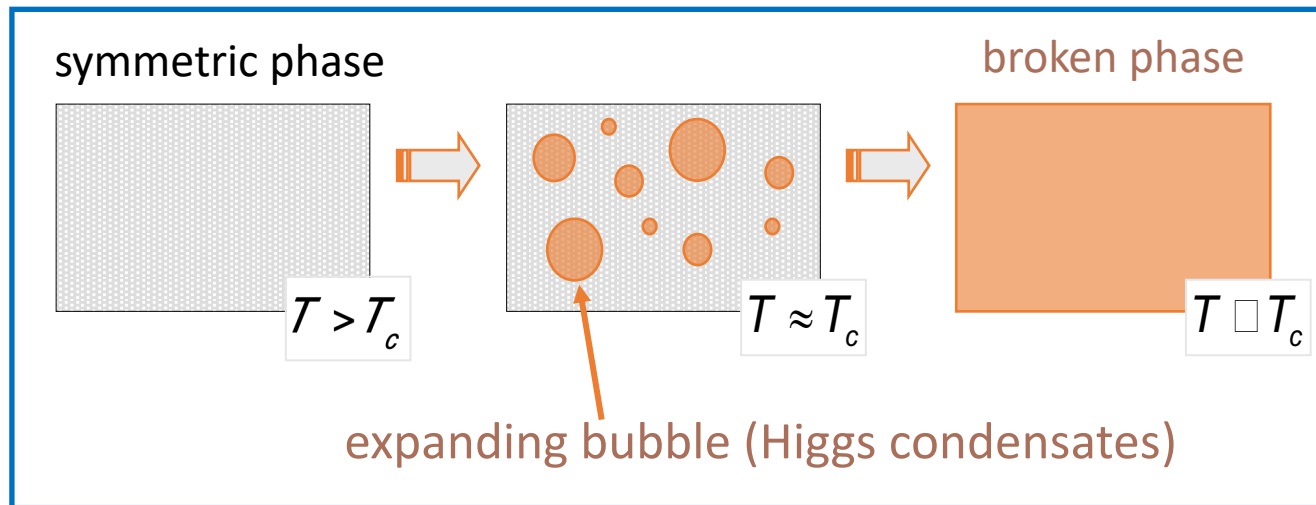

Expanding bubbles of broken phase
In a medium of symmetric phase

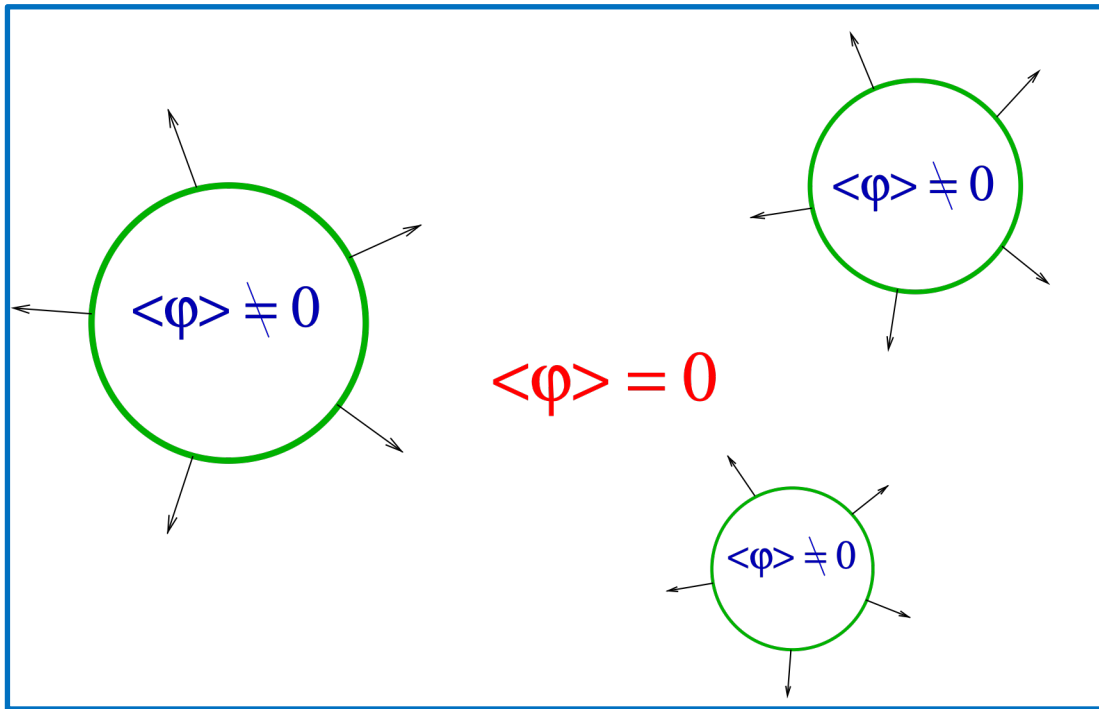

Baryon production in
front of bubble wall

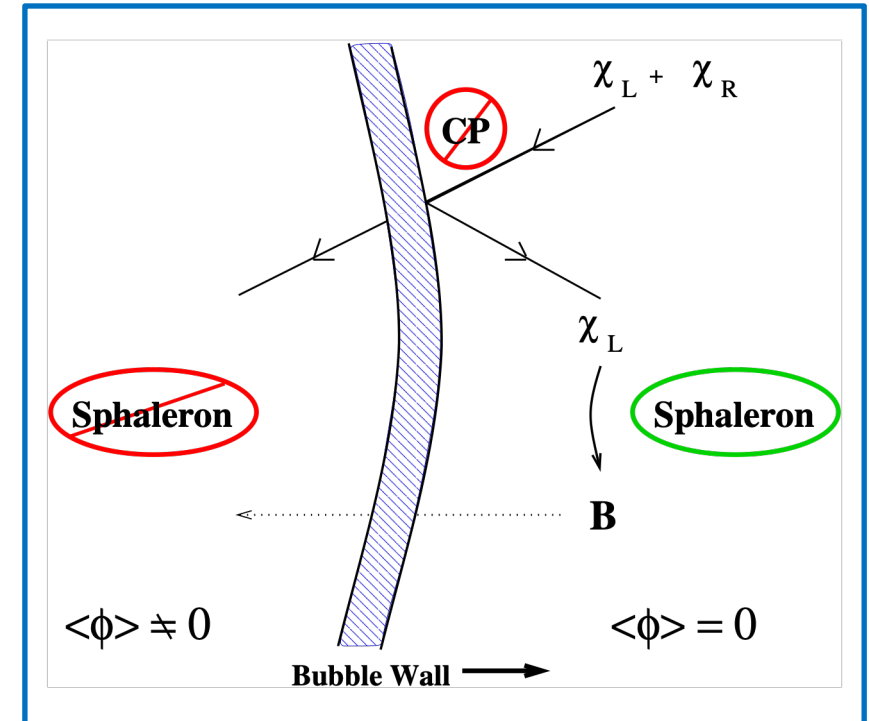

→ Was the phase transition in the early universe of 1st order?
→ Higgs potential?

→ If new physics is abundant in thermal plasma of early universe:
→ Likely to be of TeV energy scale.

- Sacharov Conditions
 - ✓ All present in S.M.

1. Baryon asymmetry

✓ Baryon Number Violation

Adler-Bell-Jackiw

't Hooft, PRL 37 (1976) 8

Axial Anomaly:
 $\partial_\mu j^{\mu 5} \neq 0$

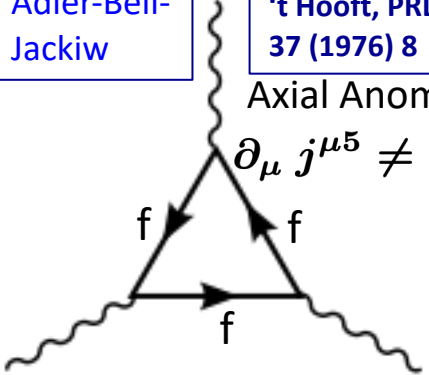

Quantum anomaly

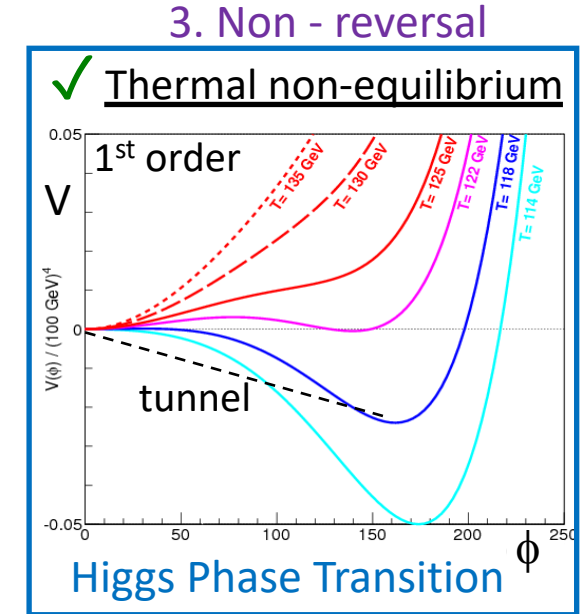
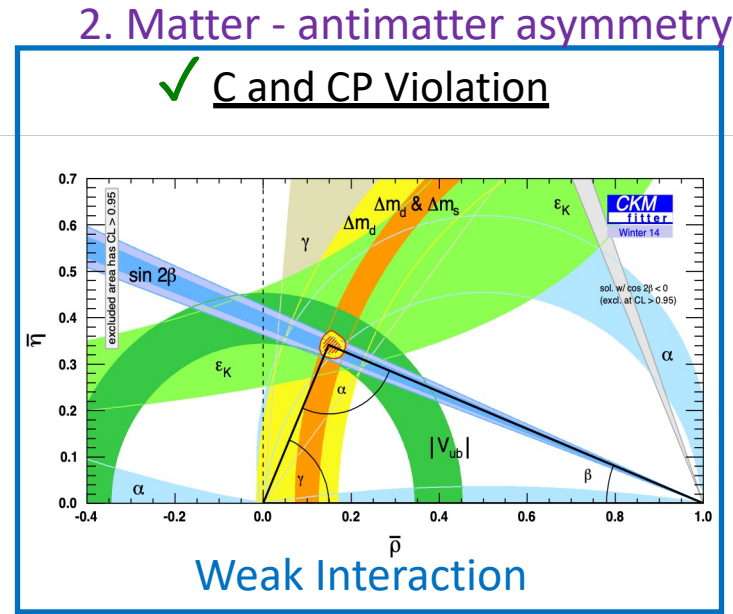

- Sacharov Conditions
 - ✓ All present in S.M.
 - ✗ Not Enough?

1. Baryon asymmetry

✓ Baryon Number Violation

Adler-Bell-Jackiw

't Hooft, PRL 37 (1976) 8

Axial Anomaly:
 $\partial_\mu j^{\mu 5} \neq 0$

Quantum anomaly

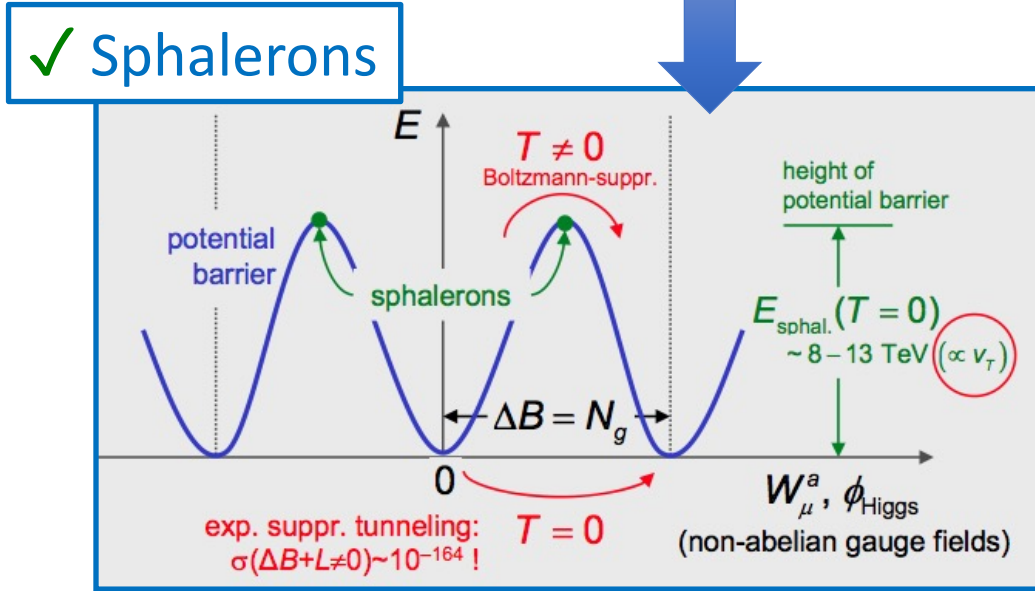
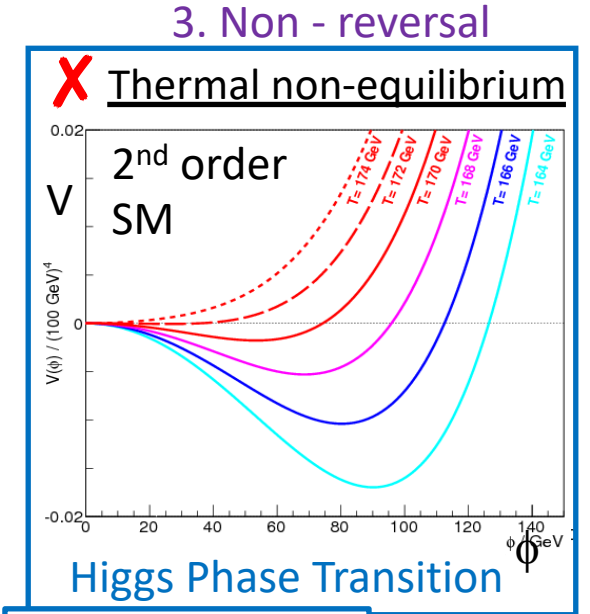
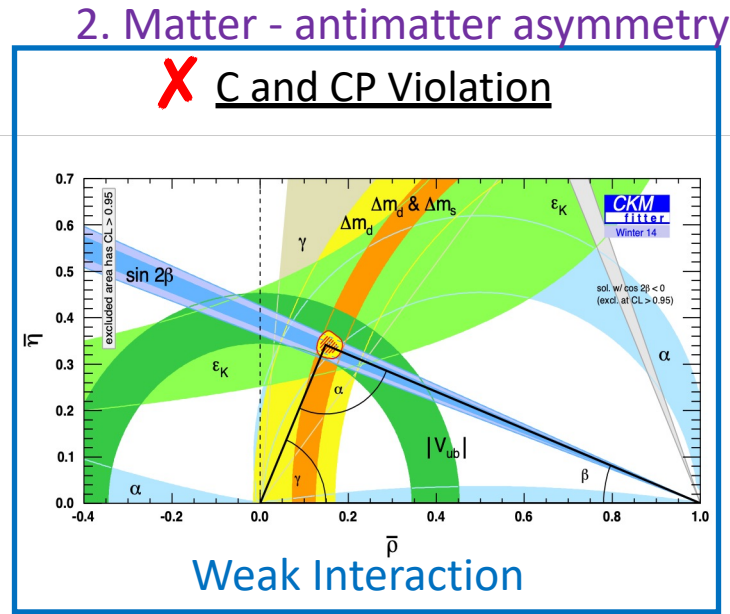

✗ CPV from CKM

- BAU: $\frac{\Delta n_B}{n_\gamma} \approx 10^{-10}$
- $A_{CP} = J_{inv} \times (m_t^2 - m_c^2)(m_c^2 - m_u^2)(m_u^2 - m_t^2) \times (m_b^2 - m_s^2)(m_s^2 - m_d^2)(m_d^2 - m_b^2)$
 - From CKM: $A_{CP}/T_C^{12} \approx 10^{-20} \rightarrow$ Too small
 - Used $T_C \sim 100$ GeV

✗ 1st order?

- SM: $M_H < \sim 70$ GeV
- THDM: $M_H \sim 125$ OK



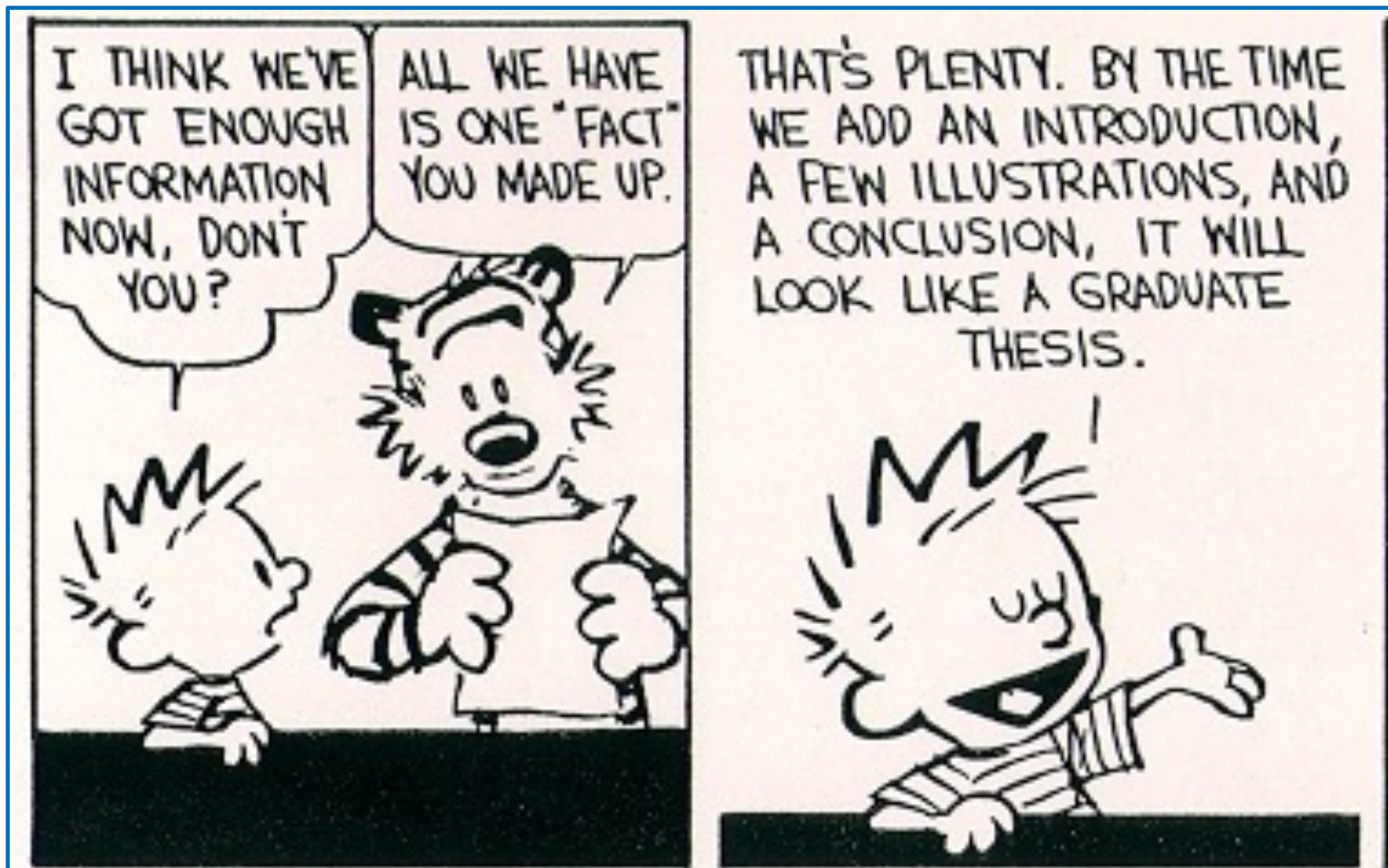

Extra

3 Generations of particles – How do we know?

LEP: The heavy Z boson decays into 3 light neutrino types.

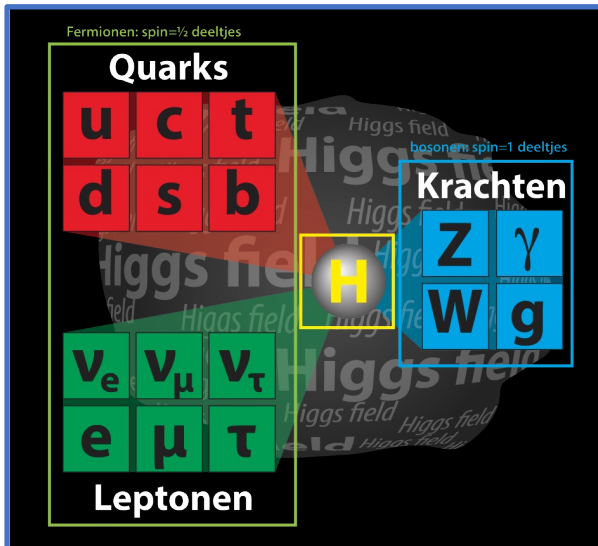
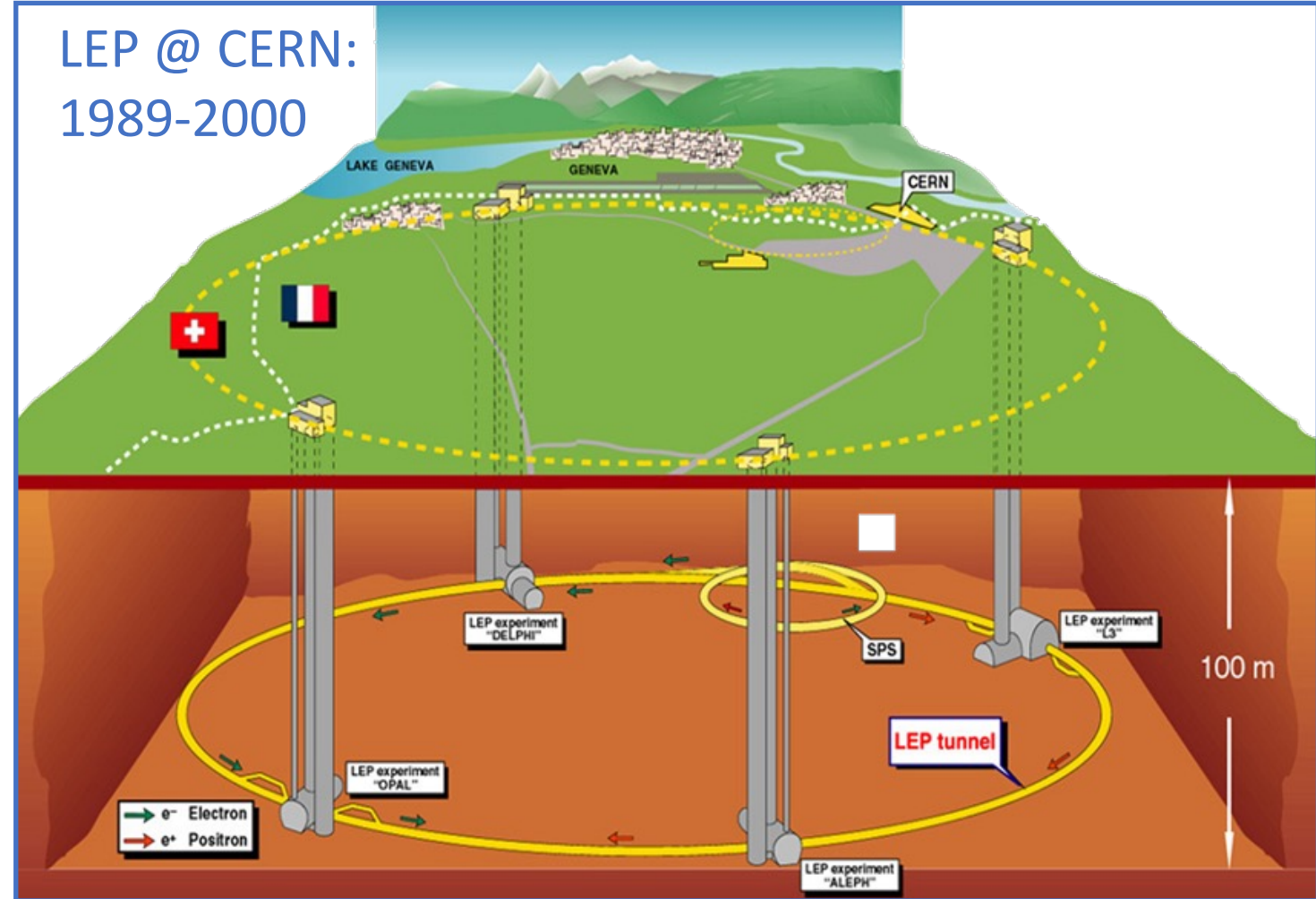
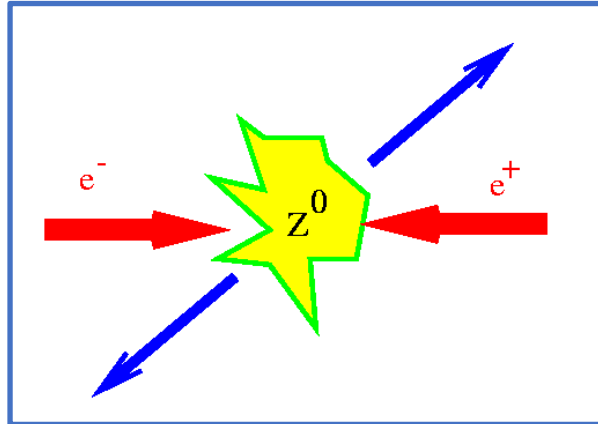

- *No additional weakly interacting light fermion generations.*

LEP: The heavy Z boson decays into 3 light neutrino types.

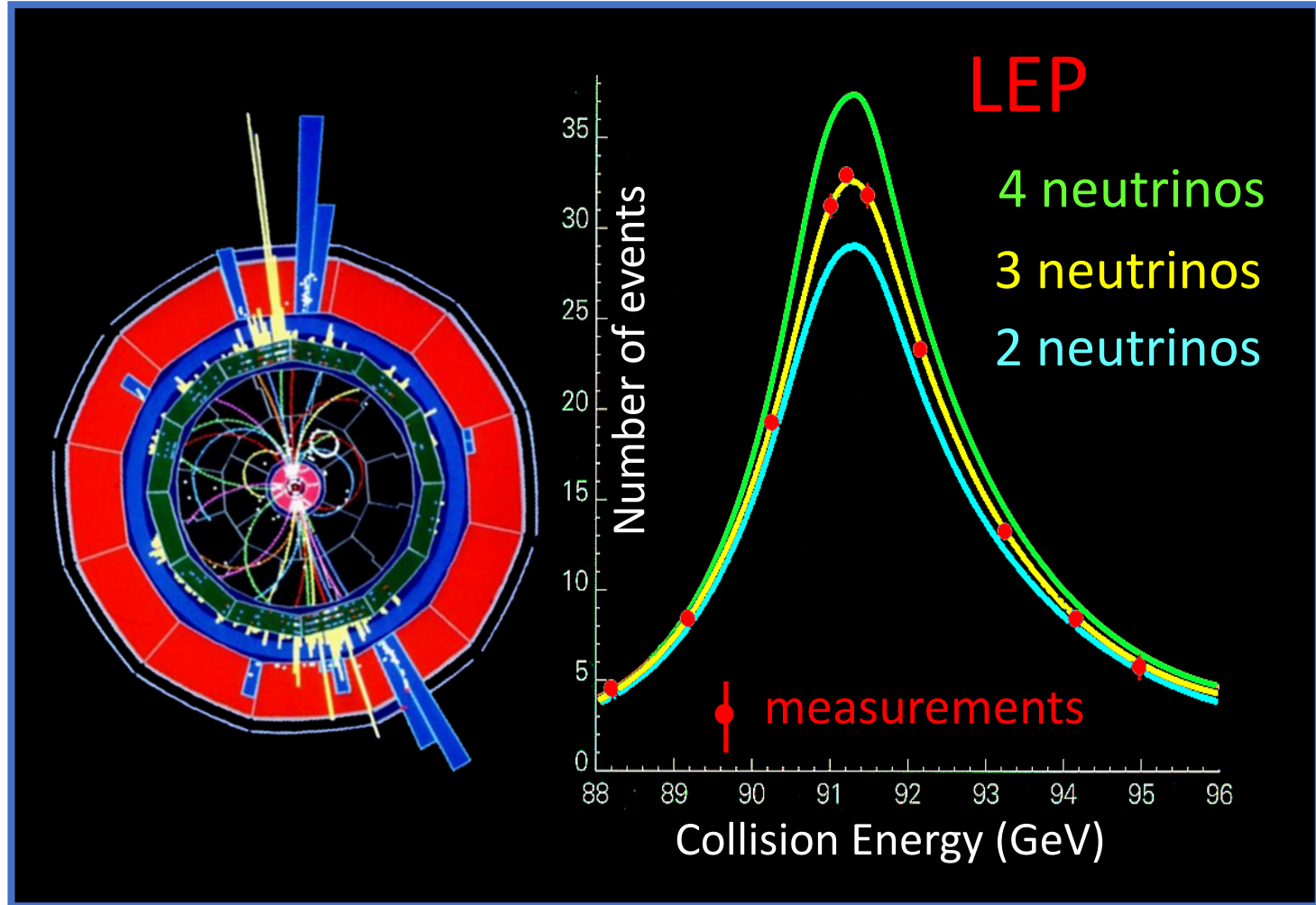
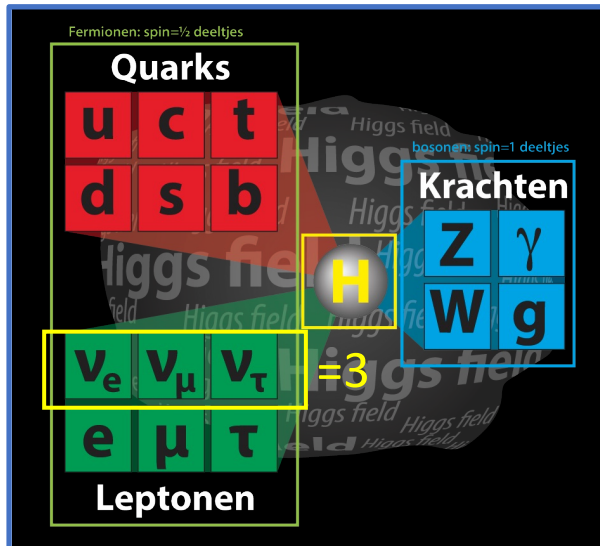
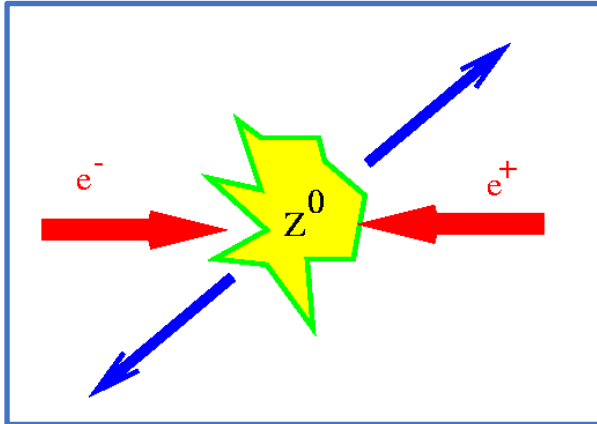

- *No additional weakly interacting light fermion generations.*

LHC: Higgs production:

Loop diagram is proportional to the mass of the heaviest fermion.

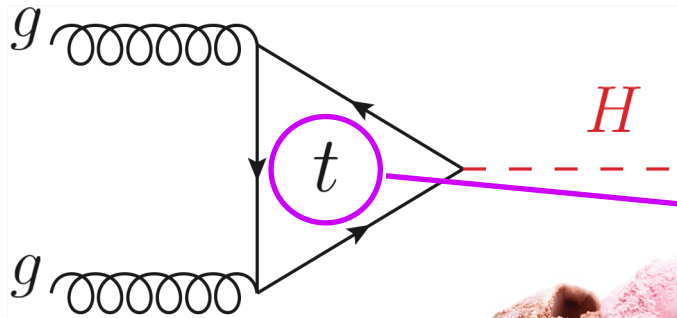

- Top is the *heaviest fermion flavour*.
- 3 Flavour generations

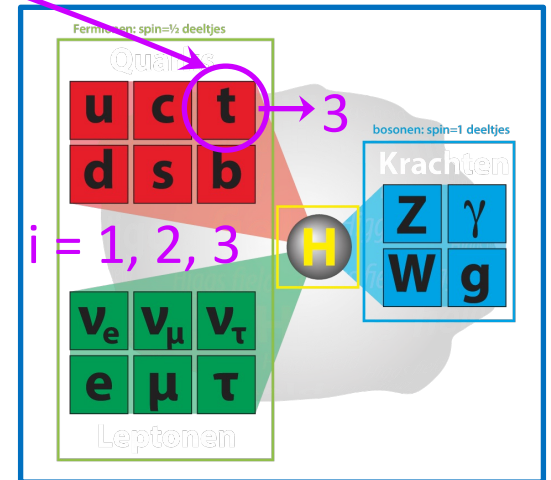
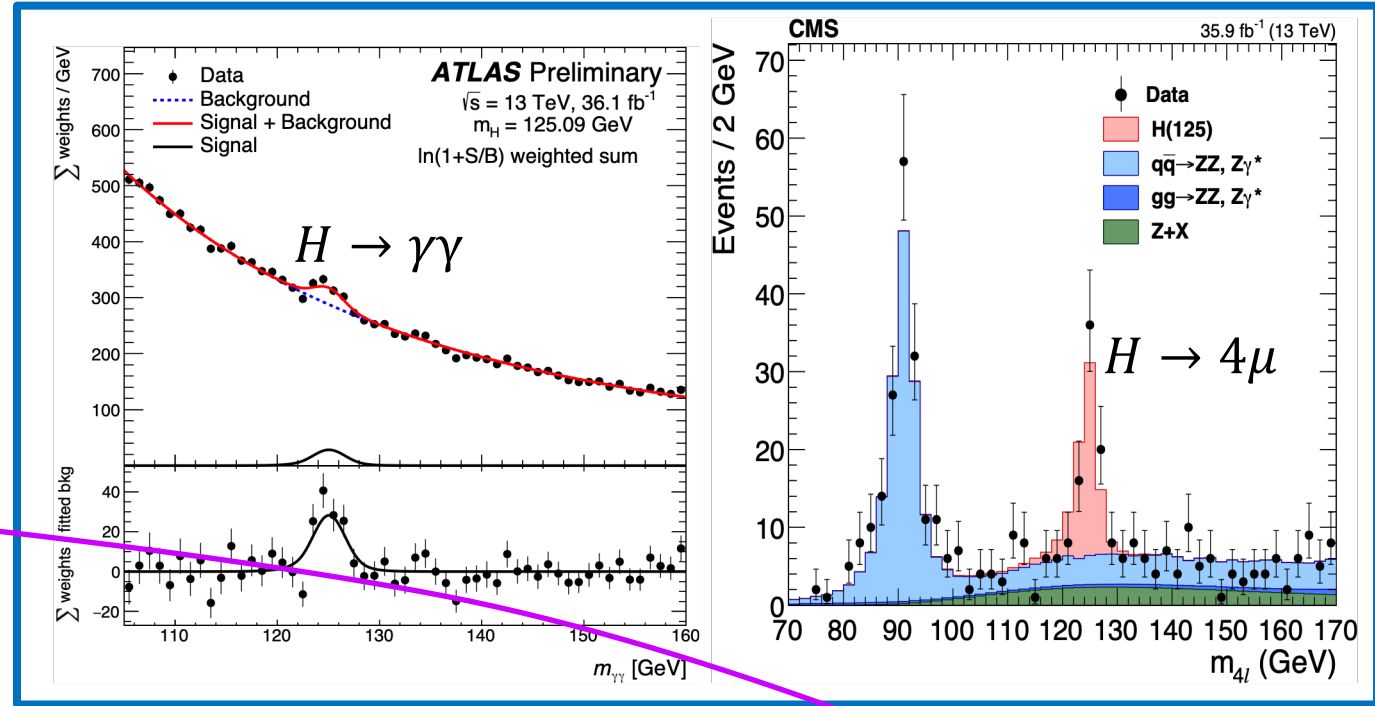

- Equivalent of CKM-Matrix V_{CKM} for leptons is PMNS-Matrix
 - Pontecorvo-Maki-Nakagawa-Sakata matrix: U_{PMNS}

- Neutrinos: U_{PMNS}

$$\begin{pmatrix} \nu_e \\ \nu_\mu \\ \nu_\tau \end{pmatrix} = \begin{pmatrix} U_{e1} & U_{e2} & U_{e3} \\ U_{\mu1} & U_{\mu2} & U_{\mu3} \\ U_{\tau1} & U_{\tau2} & U_{\tau3} \end{pmatrix} \begin{pmatrix} \nu_1 \\ \nu_2 \\ \nu_3 \end{pmatrix}$$

$$U_{MNSP} \approx \begin{pmatrix} 0.82 & 0.55 & 0.15 \\ 0.37 & 0.57 & 0.70 \\ 0.39 & 0.59 & 0.69 \end{pmatrix}$$

- Quarks: V_{CKM}

$$\begin{pmatrix} d' \\ s' \\ b' \end{pmatrix} = \begin{pmatrix} V_{ud} & V_{us} & V_{ub} \\ V_{cd} & V_{cs} & V_{cb} \\ V_{td} & V_{ts} & V_{tb} \end{pmatrix} \begin{pmatrix} d \\ s \\ b \end{pmatrix}$$

$$V_{CKM} = \begin{pmatrix} 0.97446 & 0.22452 & 0.00365 \\ 0.22438 & 0.97359 & 0.04214 \\ 0.00896 & 0.04133 & 0.99911 \end{pmatrix}$$

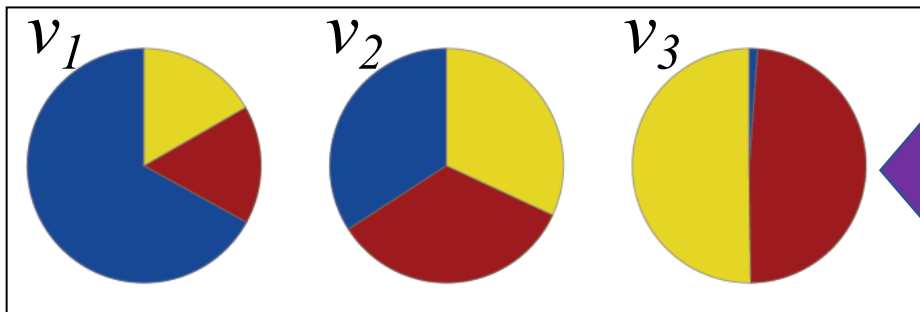

Completely different hierarchy

