

Yevgen Bilevych, Klaus Desch,
Sander van Doesburg, Harry van
der Graaf, Fred Hartjes, Jochen
Kaminski, Peter Kluit, Naomi van
der Kolk,
Cornelis Ligtenberg,
Gerhard Raven, and
Jan Timmermans

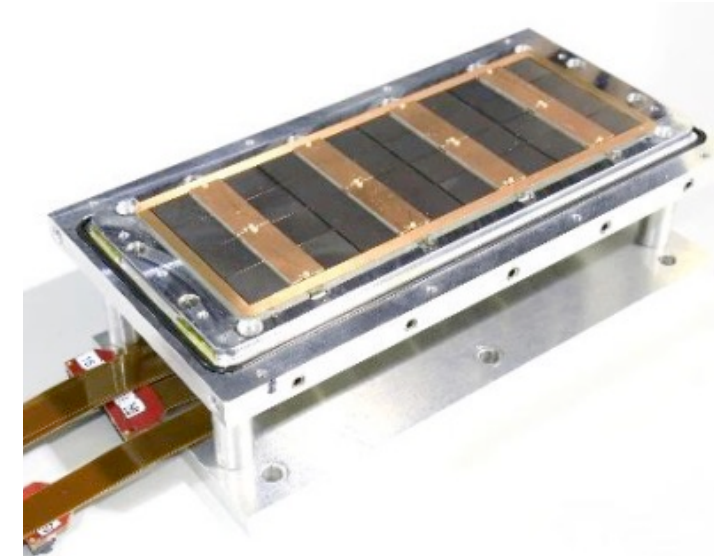

Pixel TPC

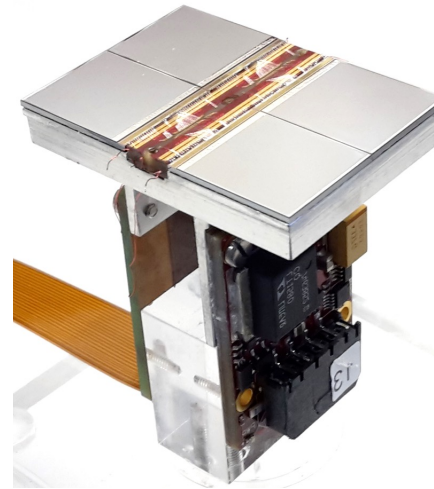
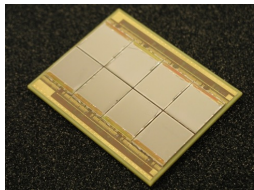

(Octopuce)

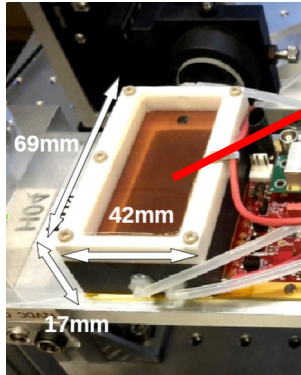

TPX3 chip

2017

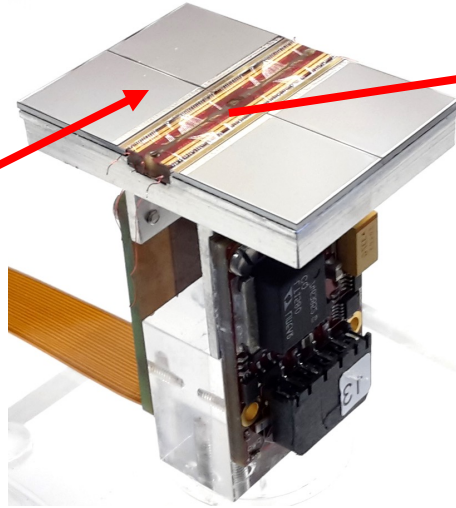

Quad

2018

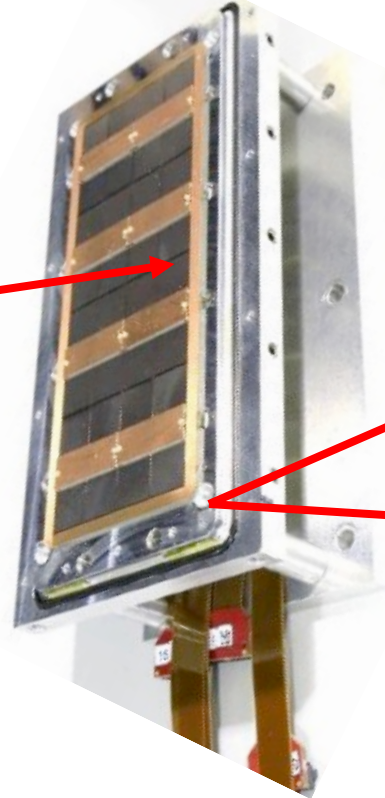

Module

2019

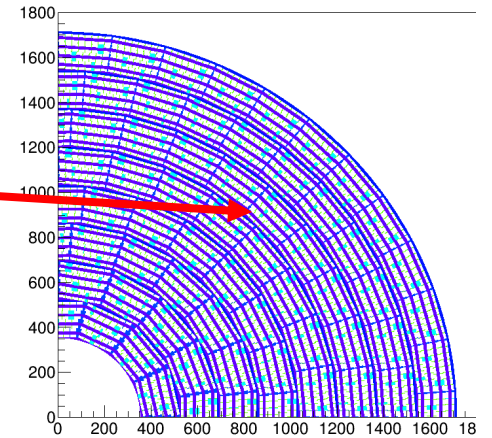
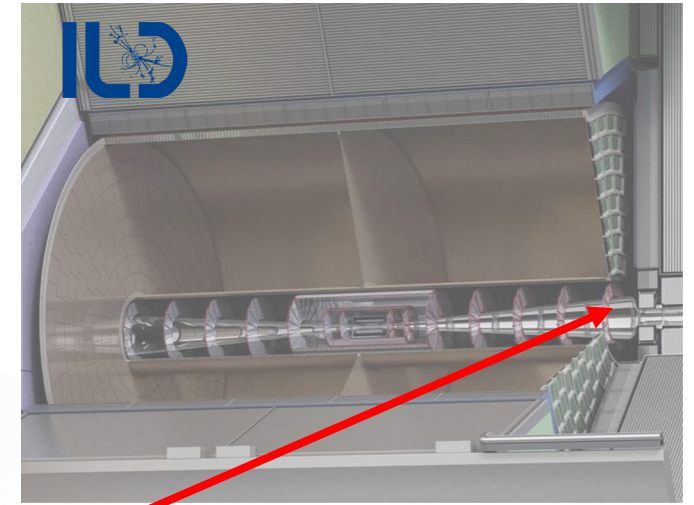

TPC plane

(TimePix1)

(2007-14)



Pixel TPC

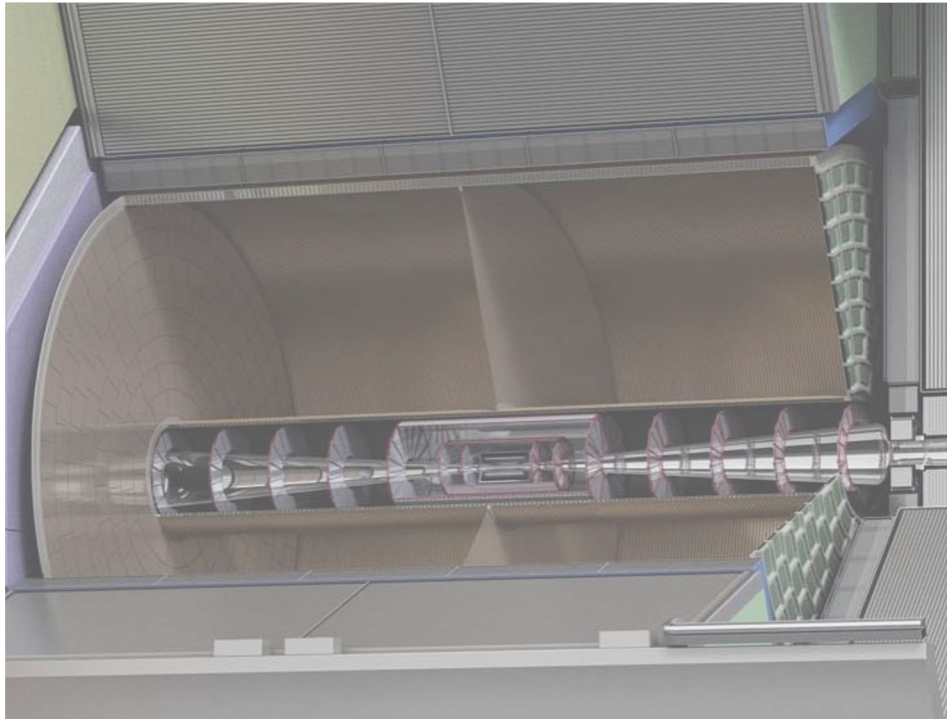

- Material budget is
 - 0.01 X_0 TPC gas
 - 0.01 X_0 inner cylinder
 - 0.03 X_0 outer cylinder
 - $< 0.25 X_0$ endplates (incl readout)
- Note the very low budget in the barrel region. Material budget can be respected by different technologies like GEM, MicroMegas and Pixels
- TPC is sliced between silicon detectors VTX, SIT and SET
- pixel readout is a serious option for the TPC readout plane @ ILC/FFC-ee/CLIC/CEPC colliders

GridPix technology

- Pixel chip with integrated Grid (Micromegas-like)
- InGrid post-processed @ IZM
- Grid set at negative voltage (300 – 600 V) to provide gas amplification
- Very small pixel size (55 μm)
- detecting individual electrons

- Aluminium grid (1 μm thick)
- 35 μm wide holes, 55 μm pitch
- Supported by SU8 pillars 50 μm high
- Grid surrounded by SU8 dyke (150 μm wide solid strip) for mechanical and HV stability

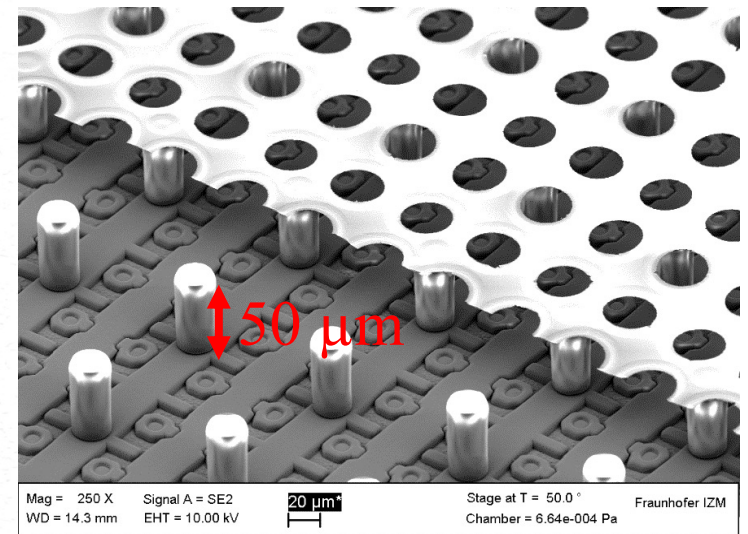
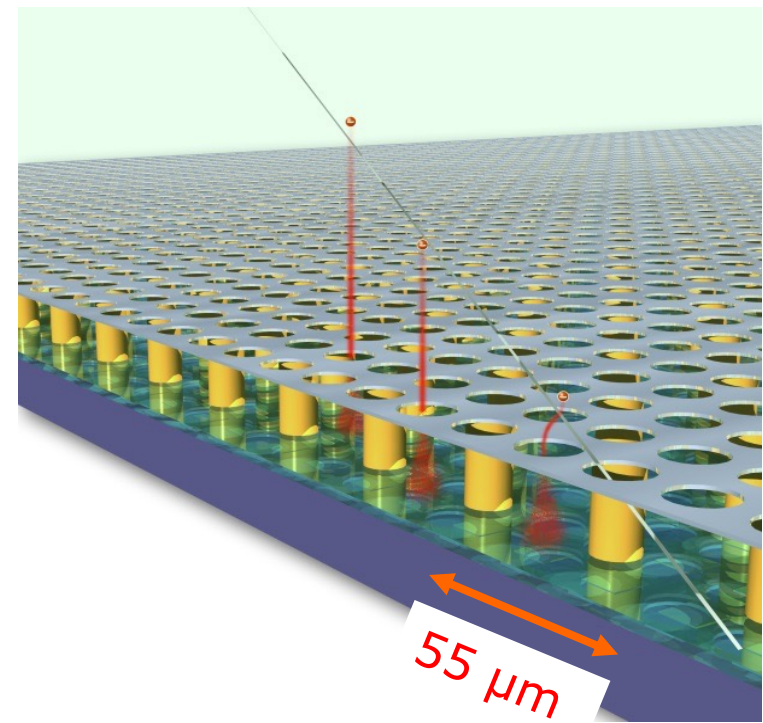
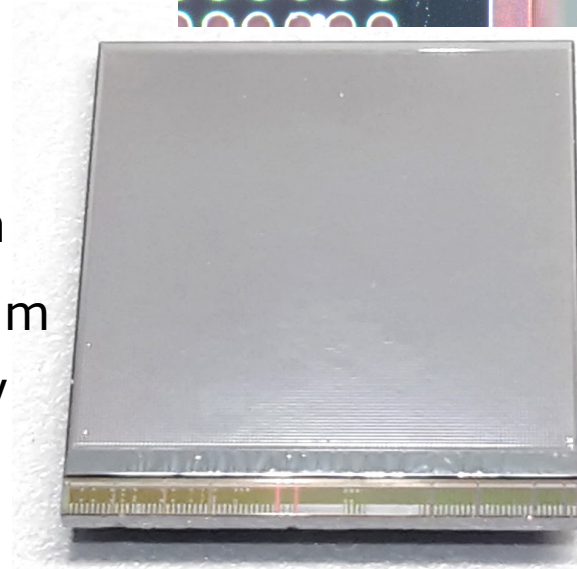
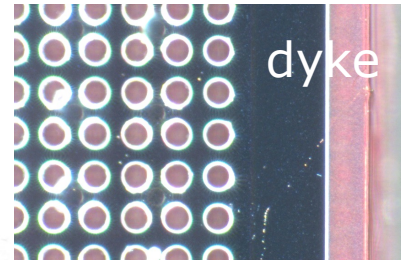

Pixel chip: TimePix3

- 256 x 256 pixels
- 55 x 55 μm pitch
- 14.1 x 14.1 mm sensitive area
- TDC with **640 MHz clock** (1.56 ns)
- Used in the data driven mode
 - Each hit consists of the **pixel address** and **time stamp** of arrival time (ToA)
 - Time over threshold (ToT) is added to register the signal amplitude
 - compensation for time walk
 - **Trigger** (for t_0) added to the data stream as an additional time stamp
- Power consumption
 - $\sim 1 \text{ A @ } 2 \text{ V}$ (2W) depending on hit rate
 - good cooling is important

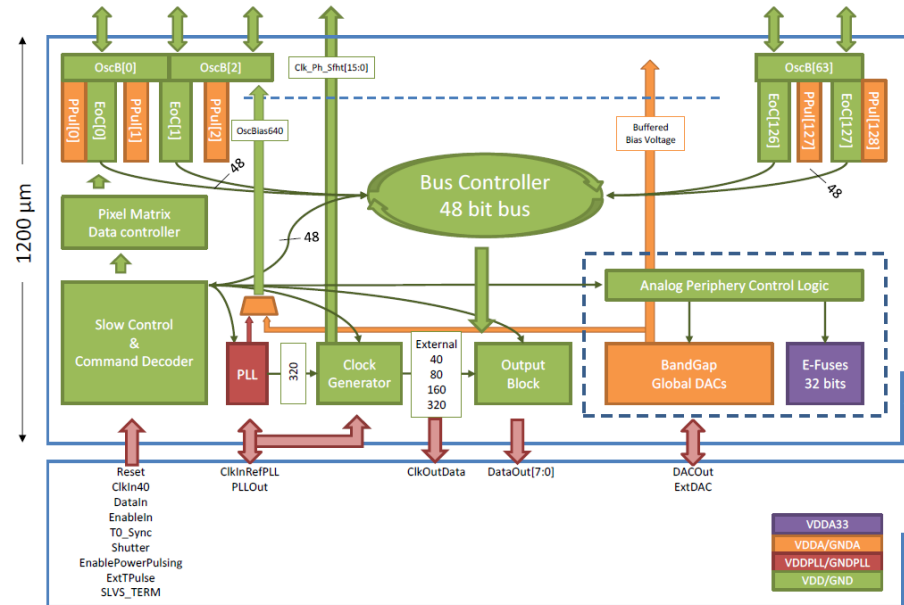

14.1 mm

2+3 mm

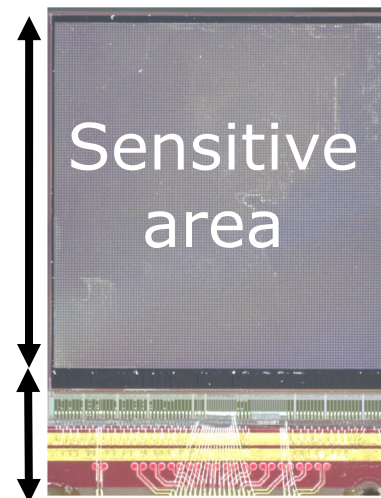

QUAD as a building block

8-QUAD module (2x4 quads) with field cage

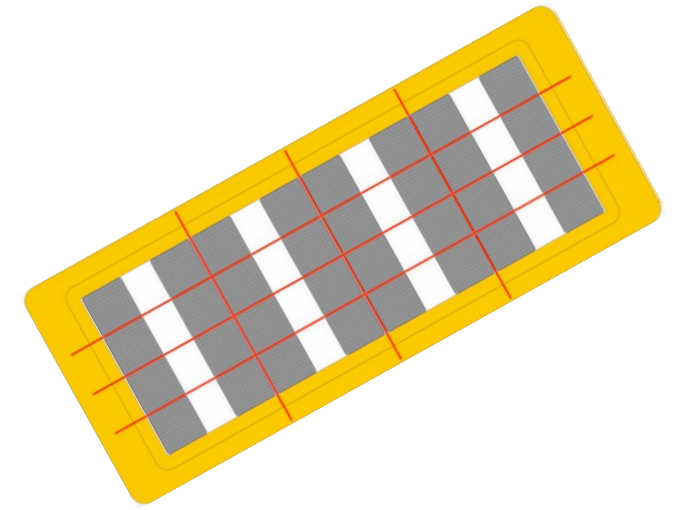
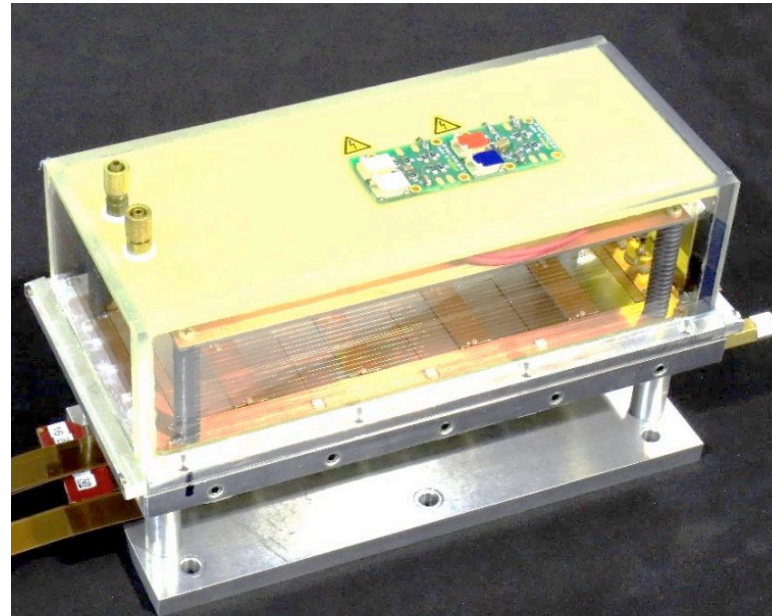
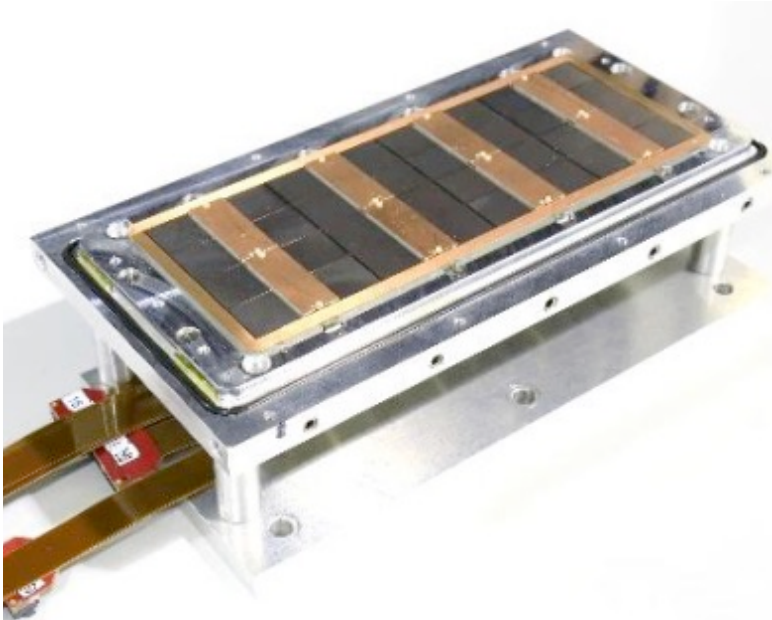

in red guard wires

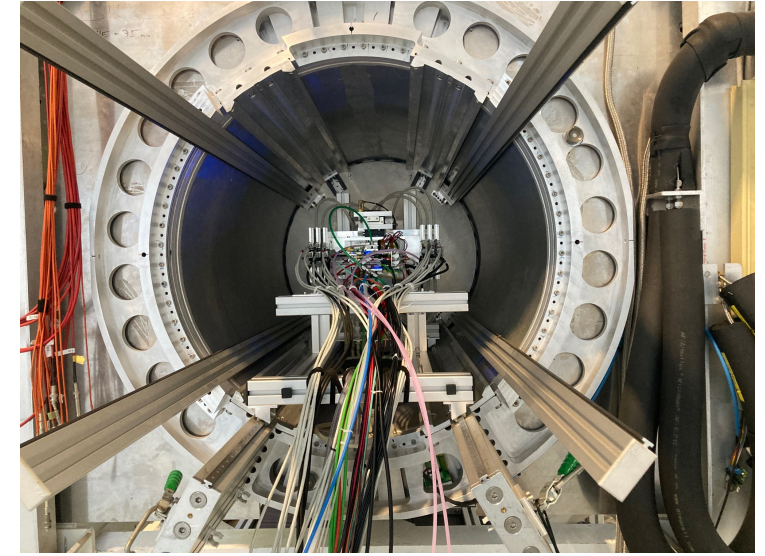
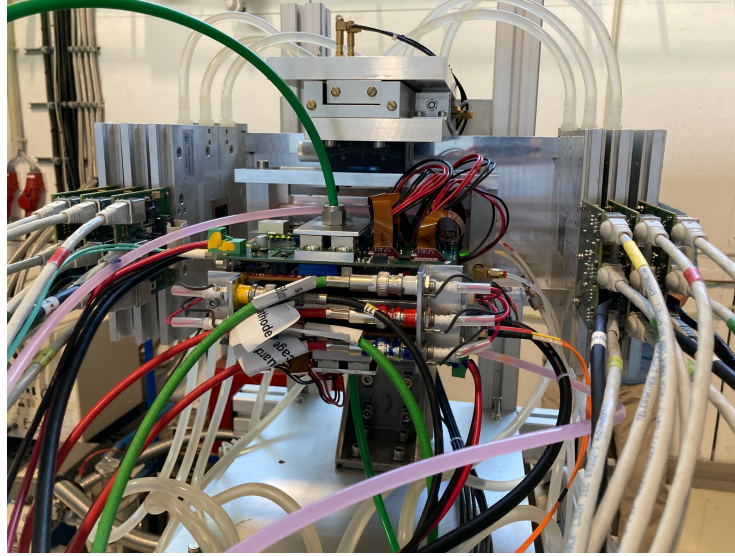
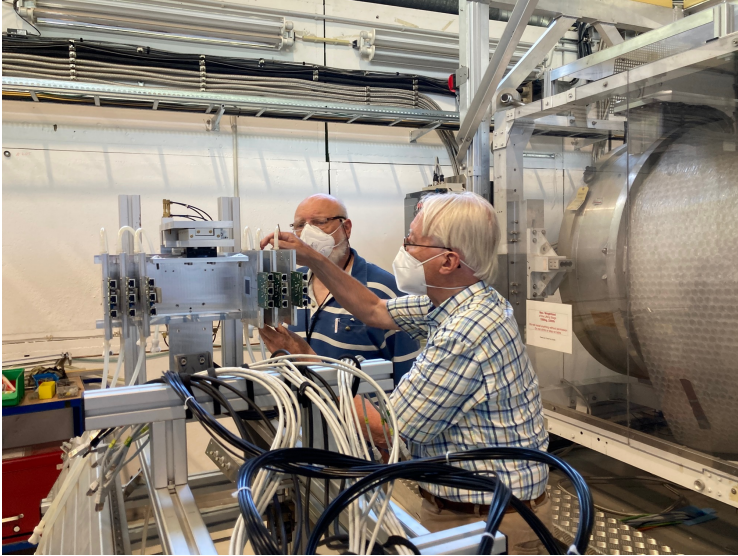

Mounting the 8 quad module between the silicon planes
sliding it into the 1 T PCMAG solenoid

DESY LCTPC-Pixel Testbeam

Run 6969 Event 2

Bfield 1.0 T beam momentum 6 GeV/c

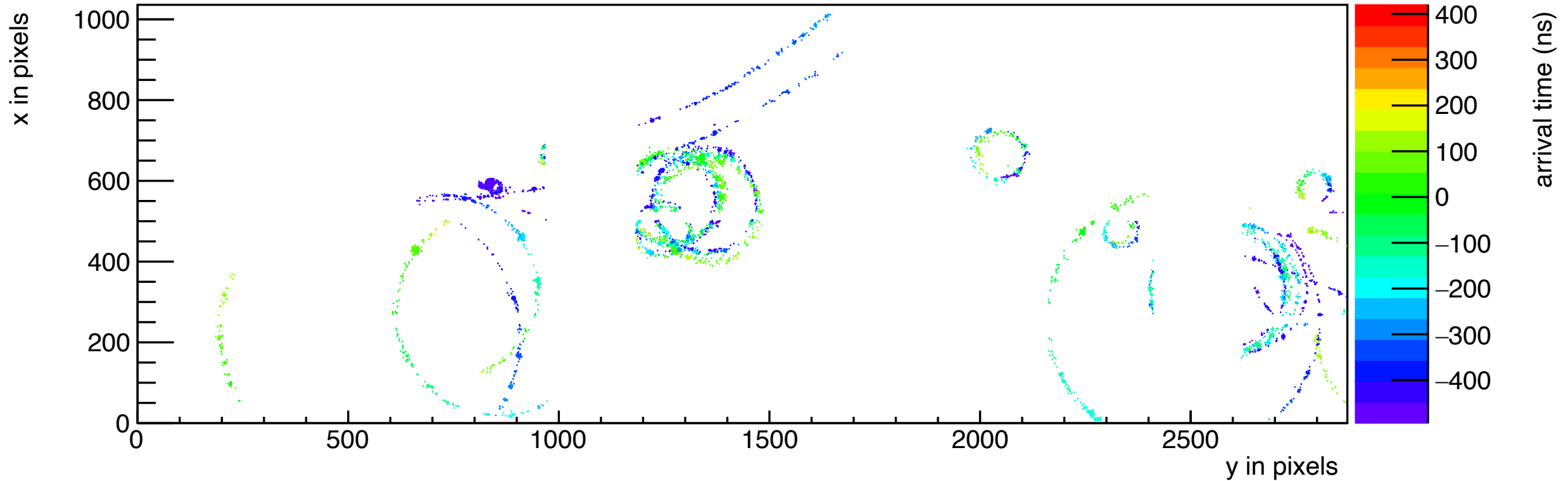

DESY LCTPC-Pixel Testbeam Run 6916 Event 12 Bfield 0 T beam momentum 6 GeV/c

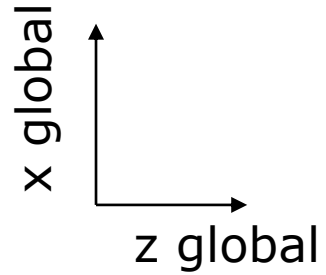

x local

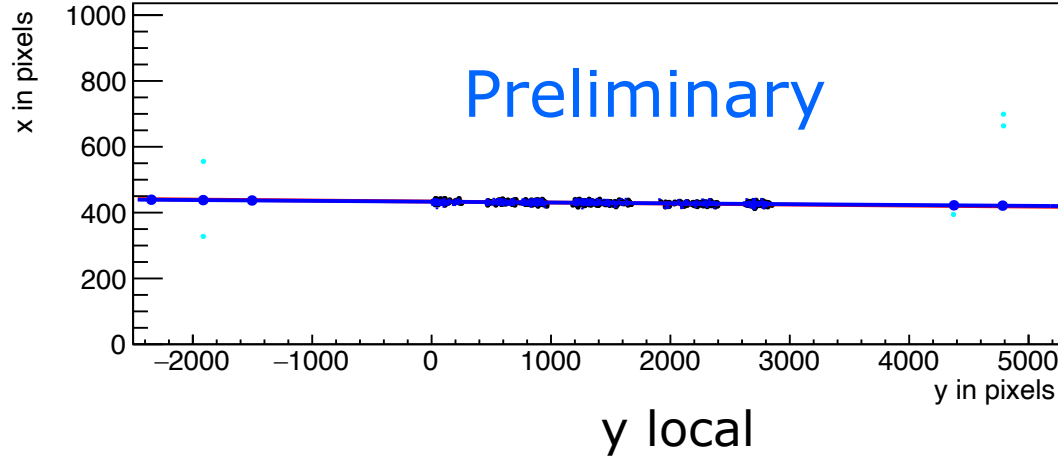

Event display with module and telescope

TPX3 track 1130 hits

$$\chi^2_{xy} = 677.5/1128$$

$$\chi^2_z = 775.9/1069$$

Asymmetric tail outlier removal applied 1071 hits in z kept.

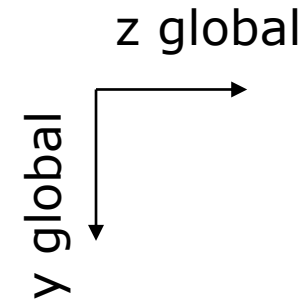

z local drift

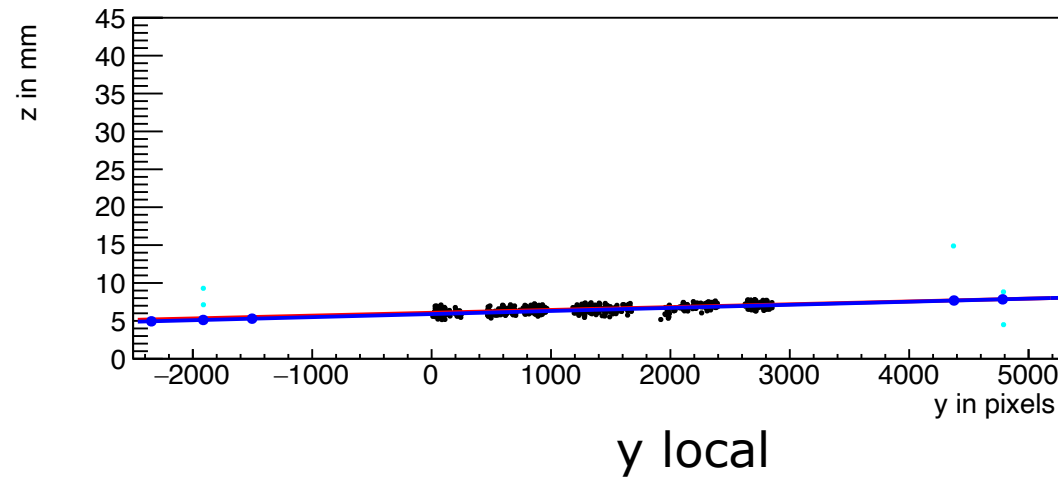

TPX3 track hits

Telescope track hits (off track green)



Run 6983-6990 B=1 T p=5 and 6 GeV

UNIVERSITÄT BONN

Fitted resolution

$$\sigma_{xy,z}^2 = \sigma_{xy0,z0}^2 + D_{xy,z}^2 (z - z_0)$$

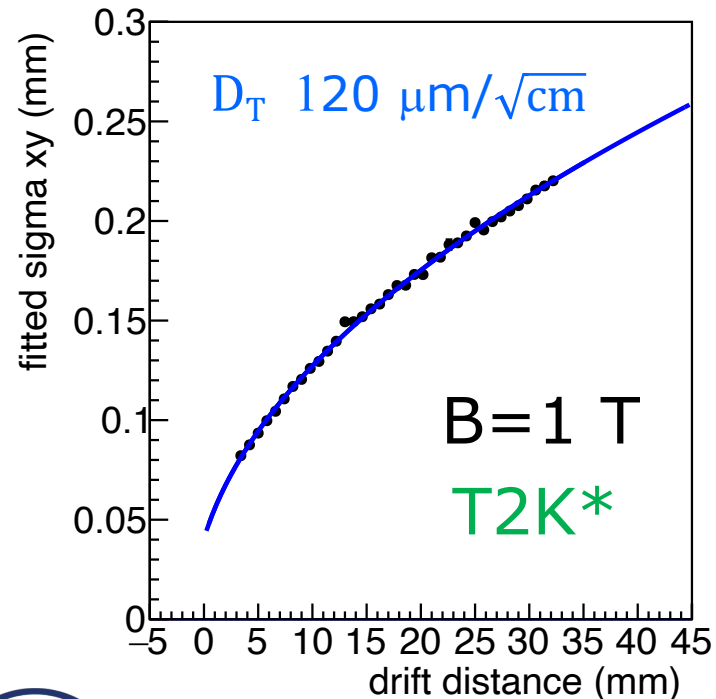

Preliminary

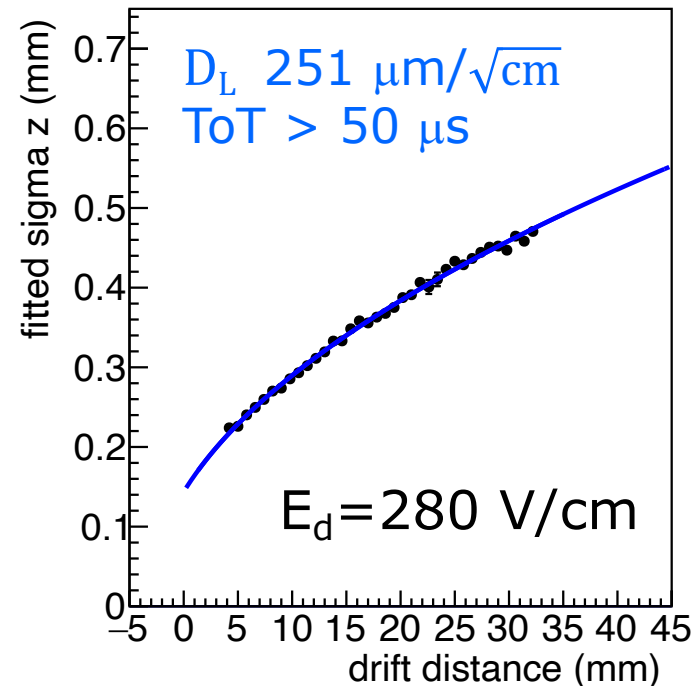

$$\sigma_{xy0}^2 = \sigma_{\text{pixel}}^2 + \sigma_{xy \text{ tele}}^2$$

$$\sigma_{\text{pixel}}^2 = 55^2/12 \mu\text{m}^2$$

$$\sigma_{xy \text{ tele}} = 42 \mu\text{m}$$

Magboltz gives for $D_T = 121 \mu\text{m}/\sqrt{\text{cm}}$

T2K* = T2K gas with O_2 and H_2O

Runs 6983-6988 B=1T p=5 GeV

Distribution of mean residuals in the plane

Method row

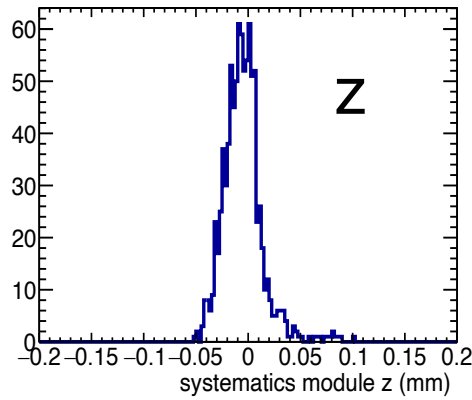
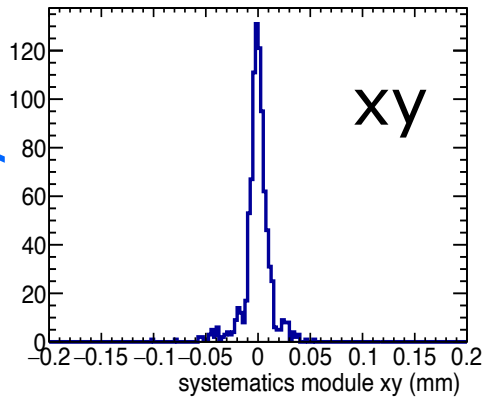

Method column

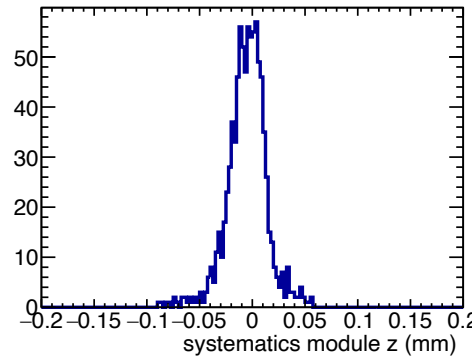
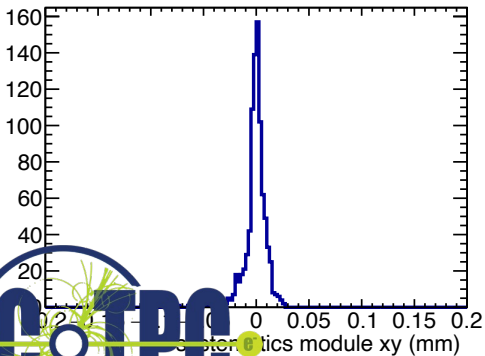

B=1 T situation

method	rms (stat) xy	bins xy	rms (stat) z	bins z
row	13 (2) μm	896	19 (5) μm	896
column	11 (2) μm	880	20 (5) μm	880

We did not include the 4 corner chips and (11), 14, 8, 13 and 19. These are affected by the field cage and the short in chip 11.

Preliminary



- Preliminary results of the 8 Quad Module in the DESY test beam in June 2021 have been presented
- In run 6916 e.g. 964 tracks were selected with 1009 hits on track
- The tracking precision: position 9 (xy) 13 μm (z) in angle 0.19 (dx/dy) 0.25 (dzdy) mrad for a module or tracklength is 157.96 mm
- The diffusion coefficients at $B=0$ T $D_{xy} = 287 \mu\text{m}/\sqrt{\text{cm}}$ $D_z = 273 \mu\text{m}/\sqrt{\text{cm}}$
- The diffusion coefficients at $B=1$ T is $D_{xy} = 120 \mu\text{m}/\sqrt{\text{cm}}$ $D_z = 251 \mu\text{m}/\sqrt{\text{cm}}$
 - In agreement with Magboltz $D_{xy} = 121 \mu\text{m}/\sqrt{\text{cm}}$

- Results for the module showed that:
 - the HV of the guard wires was well tuned
 - B=0 T rms residuals in the module plane xy $13 \mu\text{m}$ and z $15 \mu\text{m}$
 - The results are compatible with (very) high stats quad measurement
 - B= 1 T rms residuals in the plane xy $13 \mu\text{m}$ and z $20 \mu\text{m}$;
- High tracking precision is demonstrated with small systematics
 - deformations xy stay below $13 \mu\text{m}$
- Writing a NIM paper (including more results)
- More details on the results [LCTPC](#) annual gathering

* Towards a Pixel TPC: construction and test of a 32 chip GridPix detector
 M. van Beuzekom^a, Y. Bilevych^b, K. Desch^b, S. van Doesburg^a,
 H. van der Graaf^a, F. Hartjes^a, J. Kaminiski^b, P.M. Kluit^a, N. van der Kolk^a,
 C. Ligtenberg^a, G. Raven^a, J. Timmermans^a
^aNikhef, Science Park 105, 1098 XG Amsterdam, The Netherlands
^bPhysikalisches Institut, University of Bonn, Nussallee 12, 53115 Bonn, Germany

Abstract
 A Time Projection Chamber (TPC) module with 32 GridPix chips was constructed and the performance was measured using data taken in a test beam at DESY in 2021. The GridPix chips each consist of a Timepix3 chip with integrated amplification grid and have a high efficiency to detect single ionisation electrons. In the test beam setup, the module was placed in between two sets of Mimoso20 silicon detector planes that provided external high precision tracking and the whole detector setup was slid into the PCMag magnet at DESY. The analysed data were taken at electron beam energies of 5 and 6 GeV and at magnetic fields of 0 and 1 Tesla (T).

Simulation of ILD TPC with pixel readout

- To study the performance of a large pixelized TPC, the pixel readout was implemented in the full ILD DD4HEP (Geant4) simulation
- Changed the existing TPC pad readout to a pixel readout
- Adapted Kalman filter track reconstruction to pixels

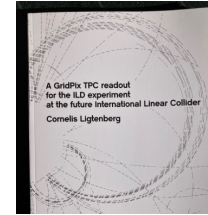

details: PhD [thesis](#)
Kees Ligtenberg

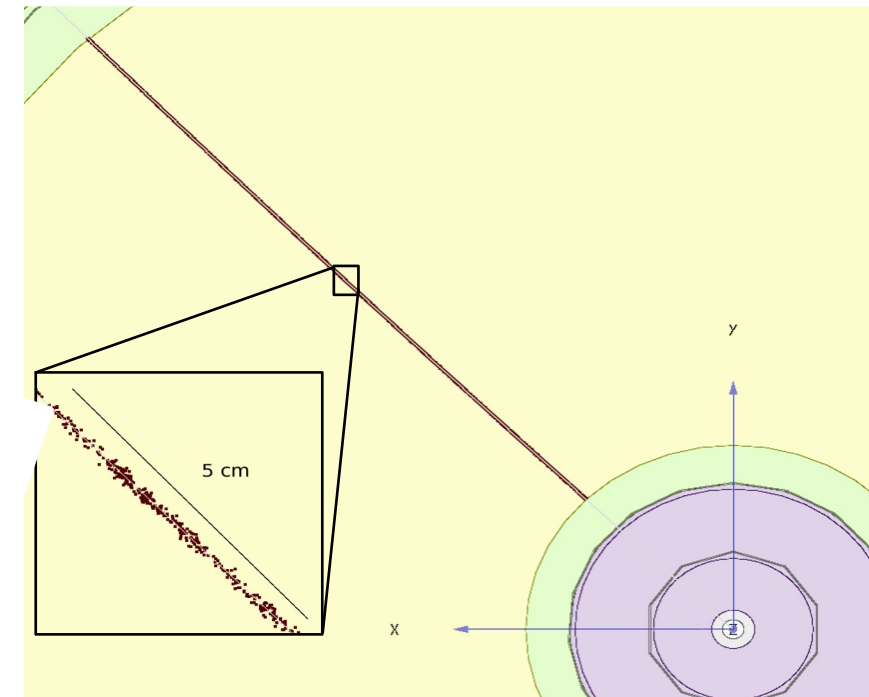
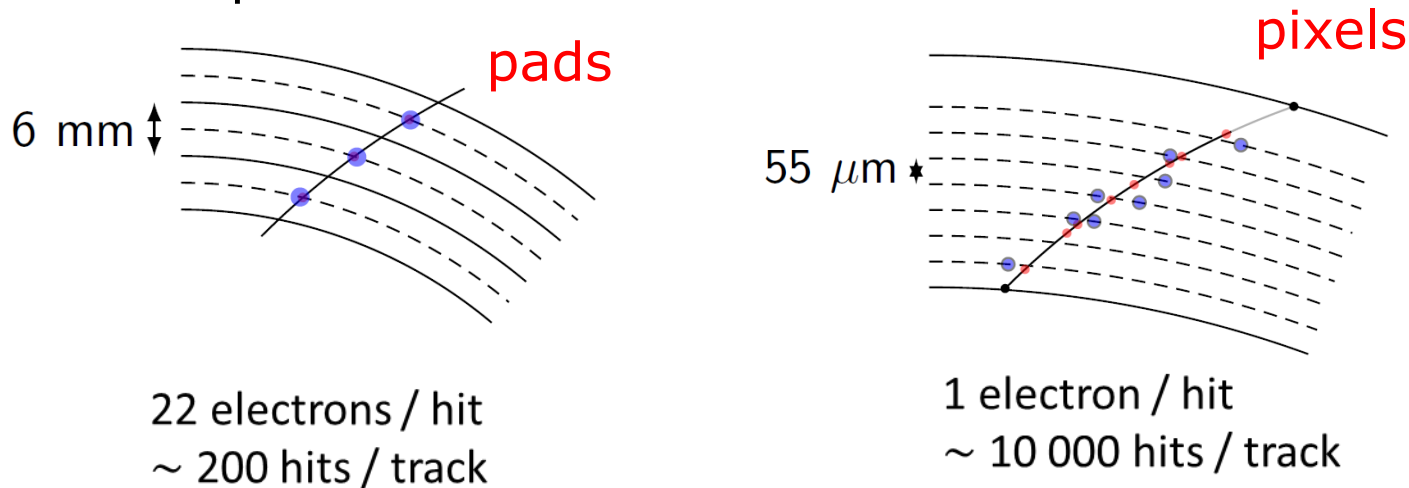

50 GeV muon track with
pixel readout

Performance of a GridPix TPC at ILC

- From full simulation the momentum resolution can be determined
- Momentum resolution is about 15% better for the pixels with realistic coverage (with the quads arranged in modules coverage 59%) and deltas.

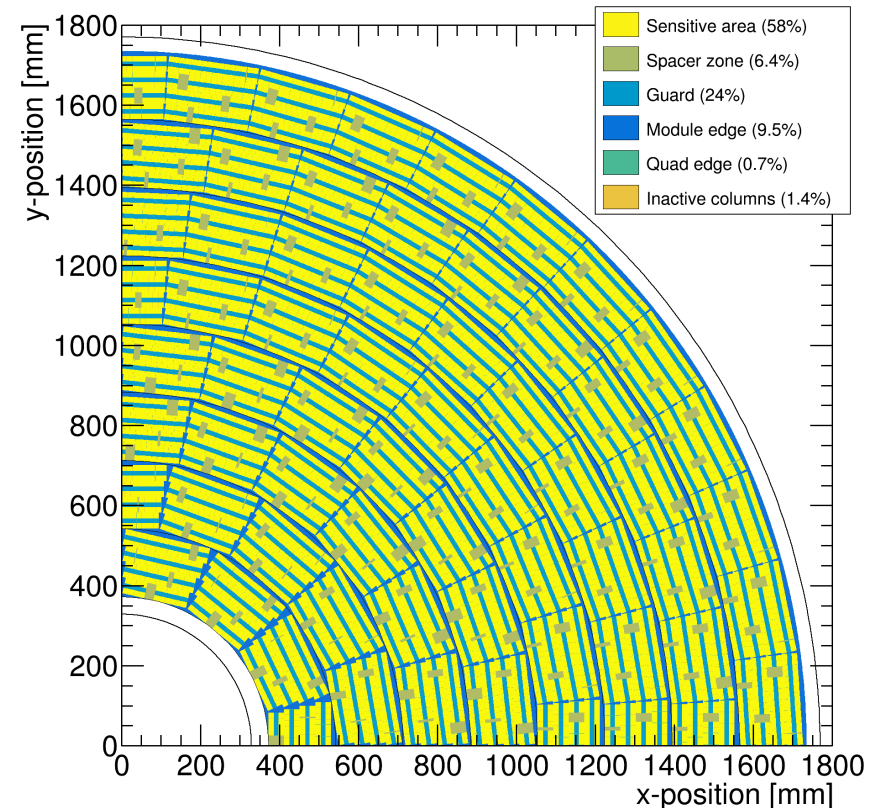
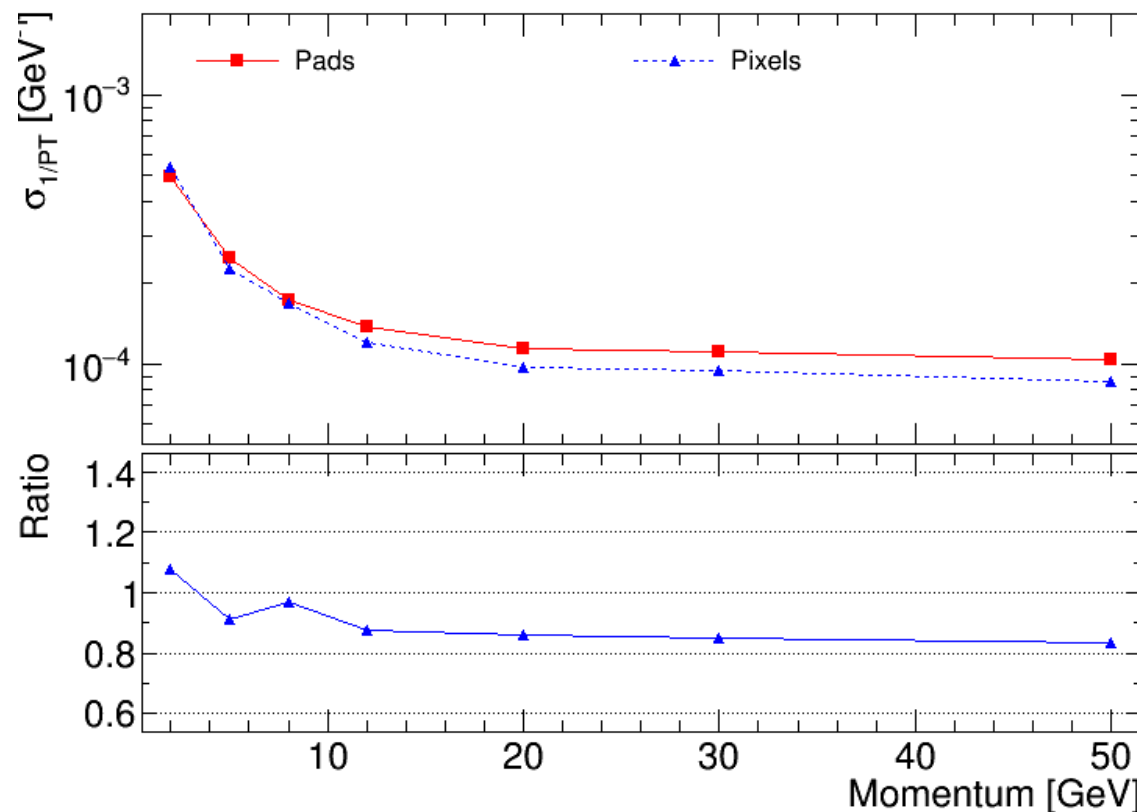

CEPC tracking Performance in xy for a Pixel TPC based on test beam

CEPC TPC T2K gas and dimensions Huirong Xi (talk)

10 cm track σ

Single electron σ_{xy}

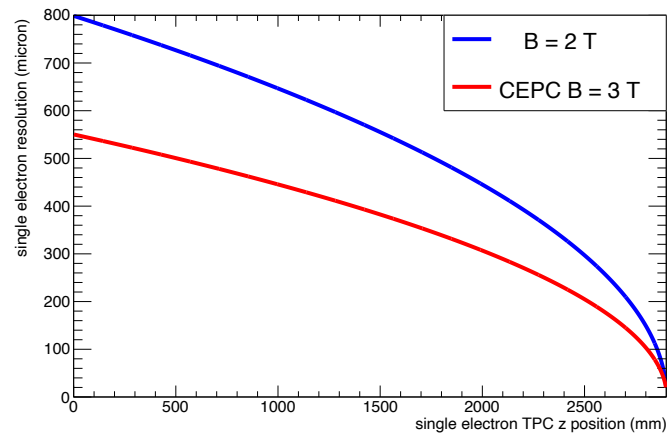

6 mm track σ

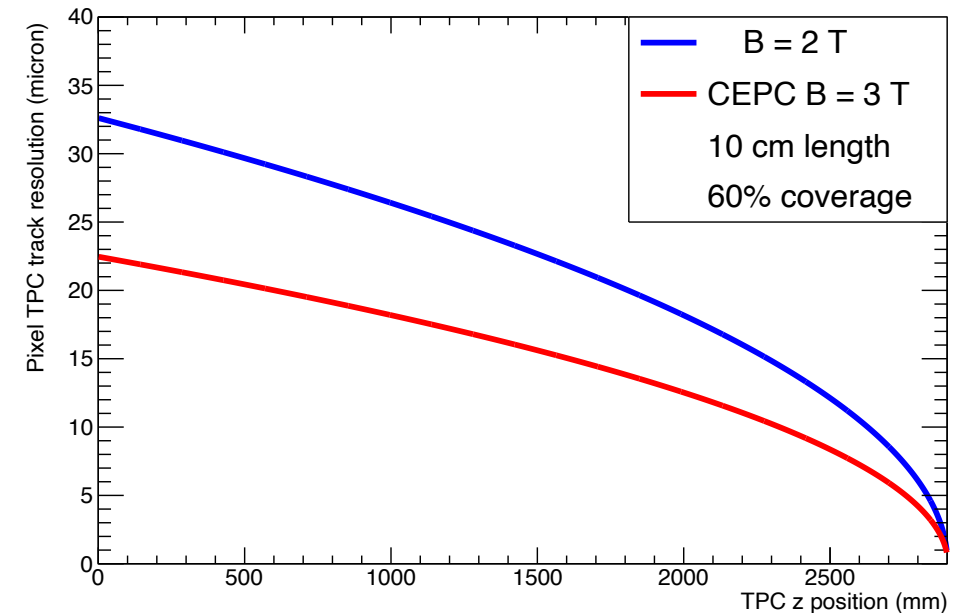
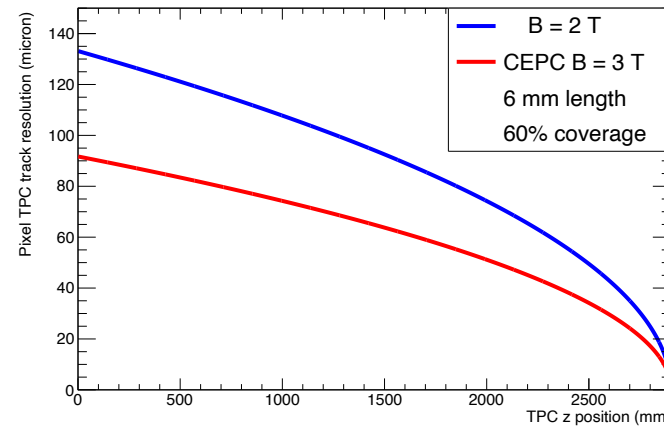

Each 10 cm we have a point with a resolution of < 22 (33) μm on the track
 Comparable to performance of silicon detector (but TPC gas material).



CEPC tracking Performance xy for a Pixel TPC based on test beam

The last 10 cm track provides very high resolution 'point' in the endcap ($\cos \theta > 0.8$). This is due to the short drift distance and the high resolution pixel readout.

This point can be used to calibrate out the TPC distortions? There is no need for an additional forward silicon tracker.

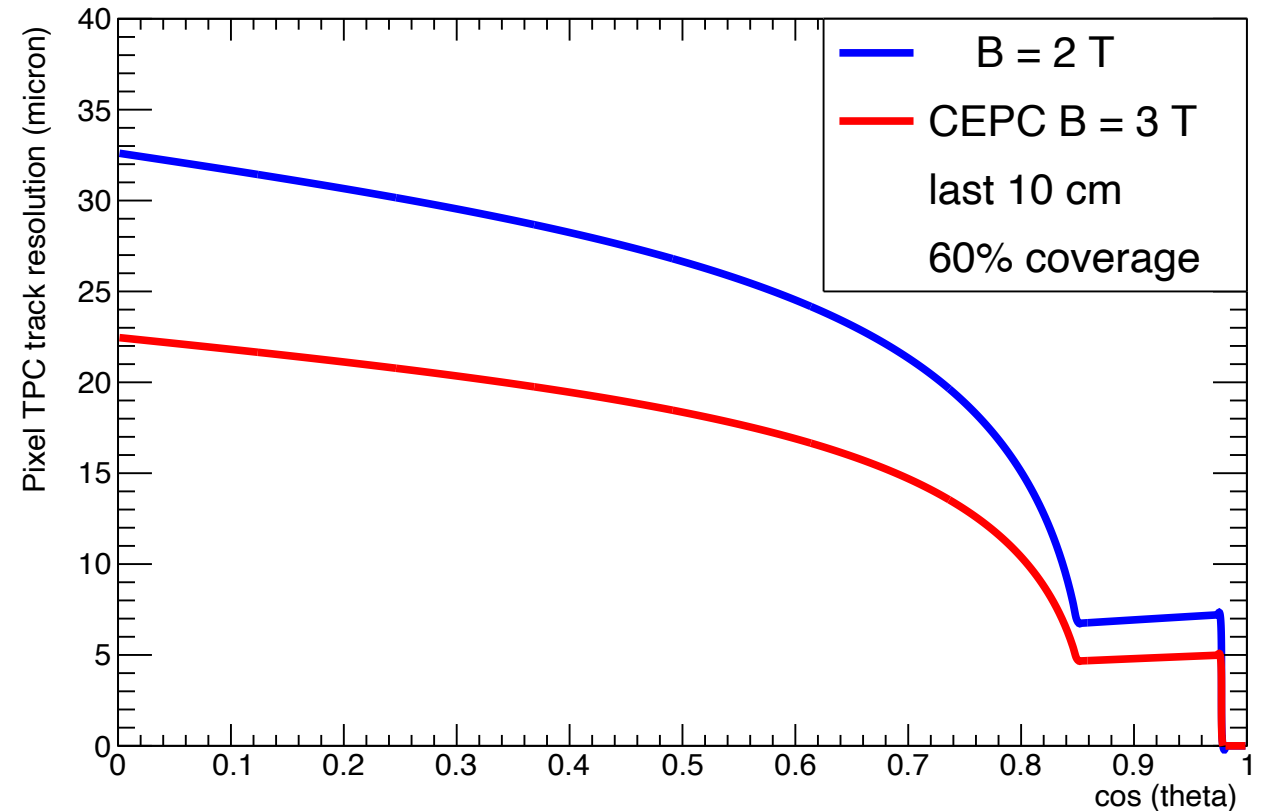

CEPC tracking Performance in z for a Pixel TPC based on test beam

10 cm track σ_z

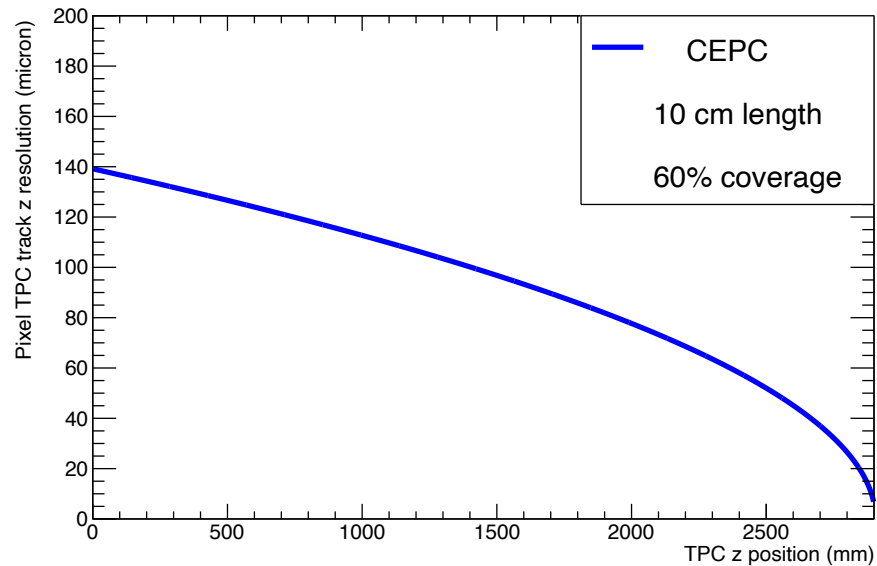

last 10 cm of track σ_z

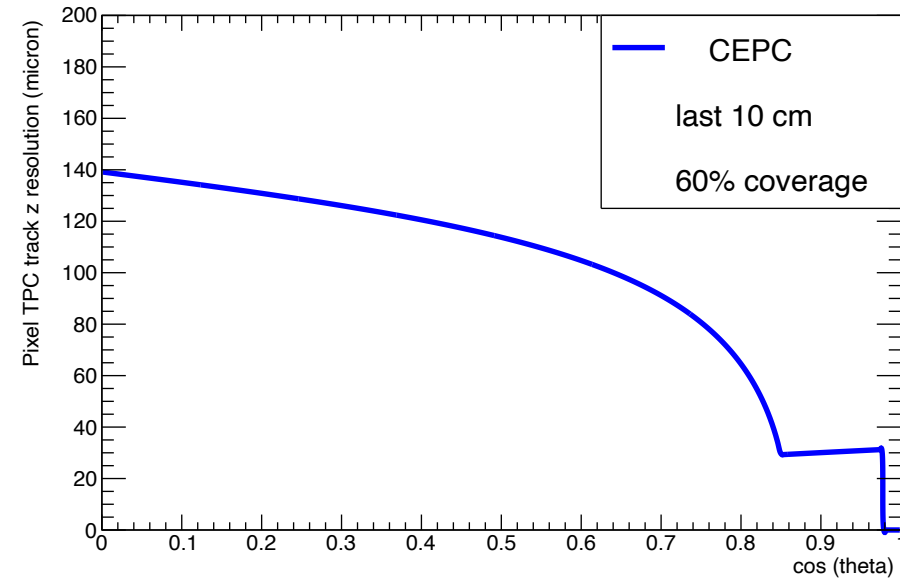

Each 10 cm we have a point with a resolution of $< 140 \mu\text{m}$ on the track
 In the endcap in the last 10 cm point $30 \mu\text{m}$



Comparison to a drift chamber IDEA with 1.8 cm cells with 66 points with resolution $\sigma(xy)$ 100 μm and $\sigma(z)$ 2000 μm

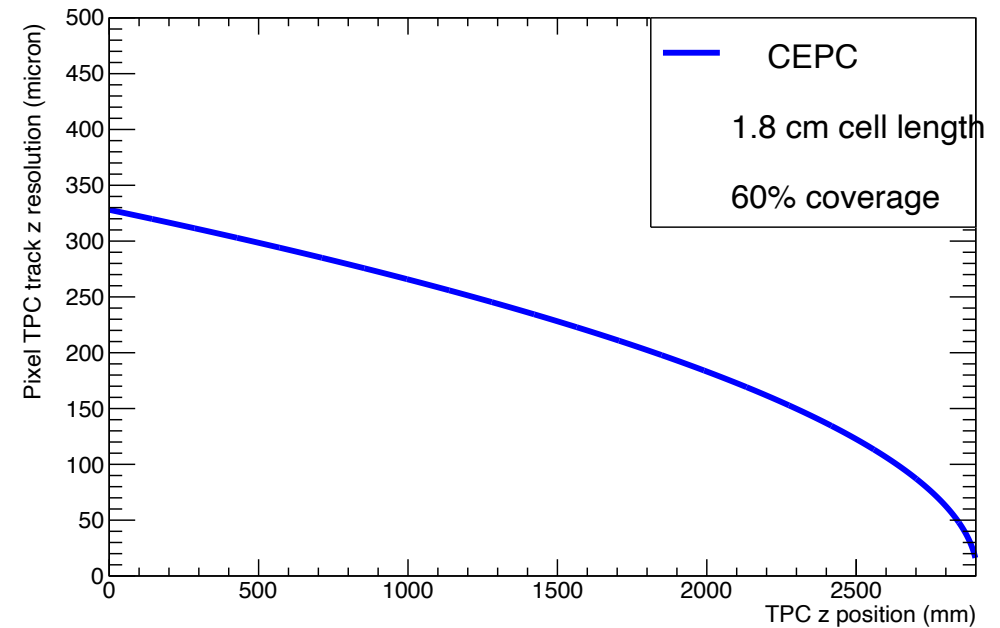
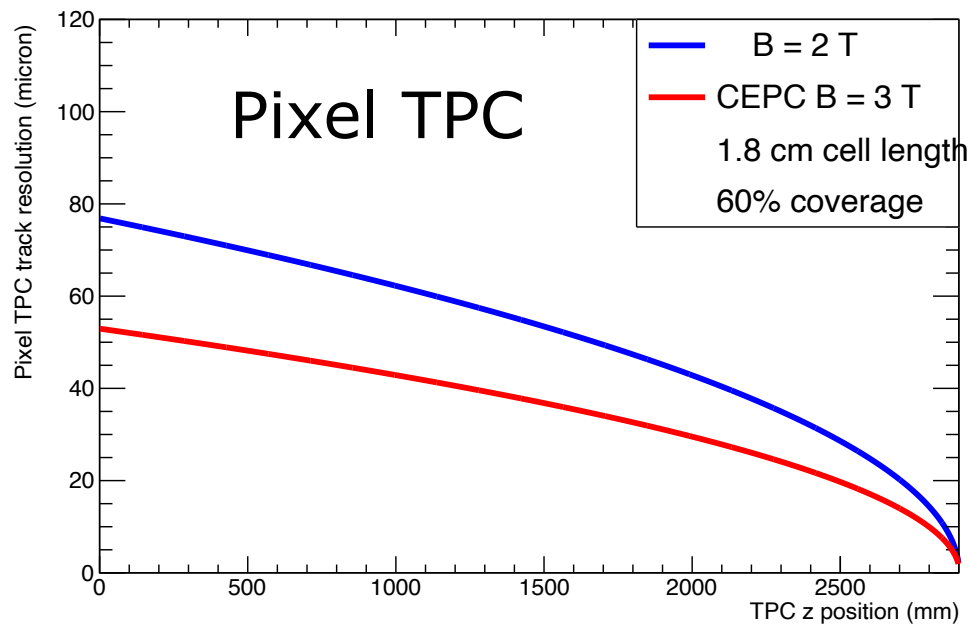

Conclusion resolutions of a (Pixel) TPC for the same "cell" size are smaller by a factor of: xy 1.2 to 10 (2 T) , 2 to 10 (3 T) and in z 3-10.

DESY LCTPC-Pixel Testbeam

Run 6969 Event 2

Bfield 1.0 T beam momentum 6 GeV/c

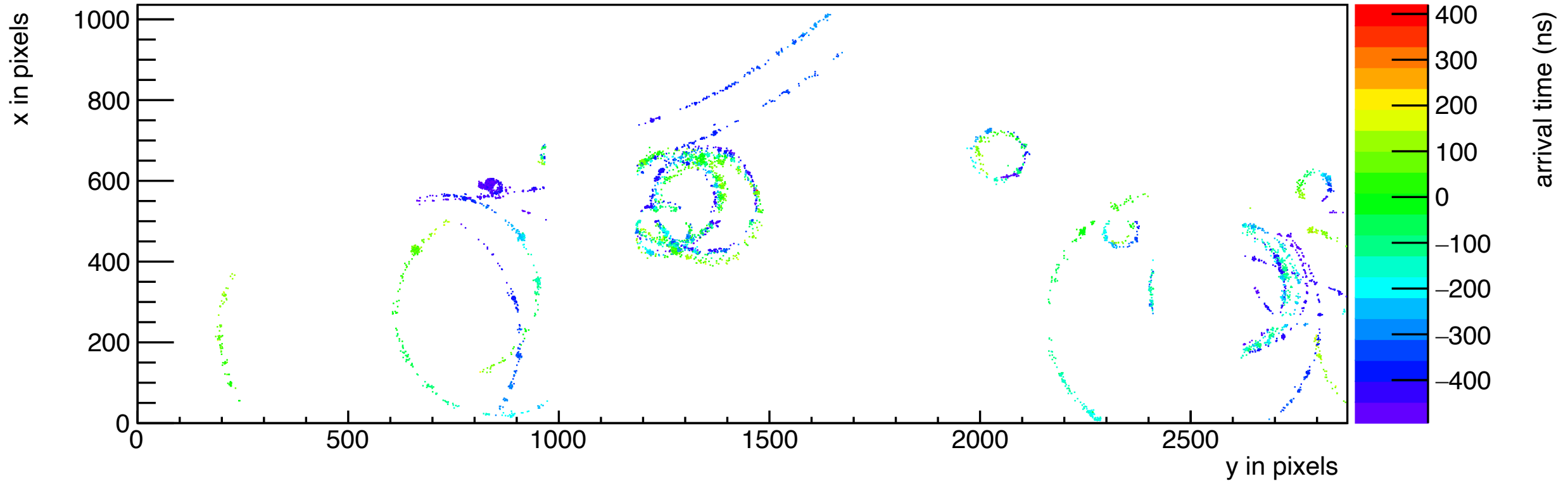

Performance of dEdx

- It is possible to study in data the energy loss of electrons
- The Pixel TPC has measurements with 55 μm pixel size
- This allows to measure the number of hits as a function of the distance along the track dN/dx (dE/dx) with high granularity
- It is possible to use also the ToT (a measure of the deposited charge) but this is not explored
- The advantage of hit counting is that one is NOT getting the fluctuations from the multiplication process. The ToT will include these avalanche fluctuations.
- Using e.g. a pad readout the charge is used as a measure of dEdx
 - This has a worse granularity and includes avalanche fluctuations

Testbeam performance of dEdx

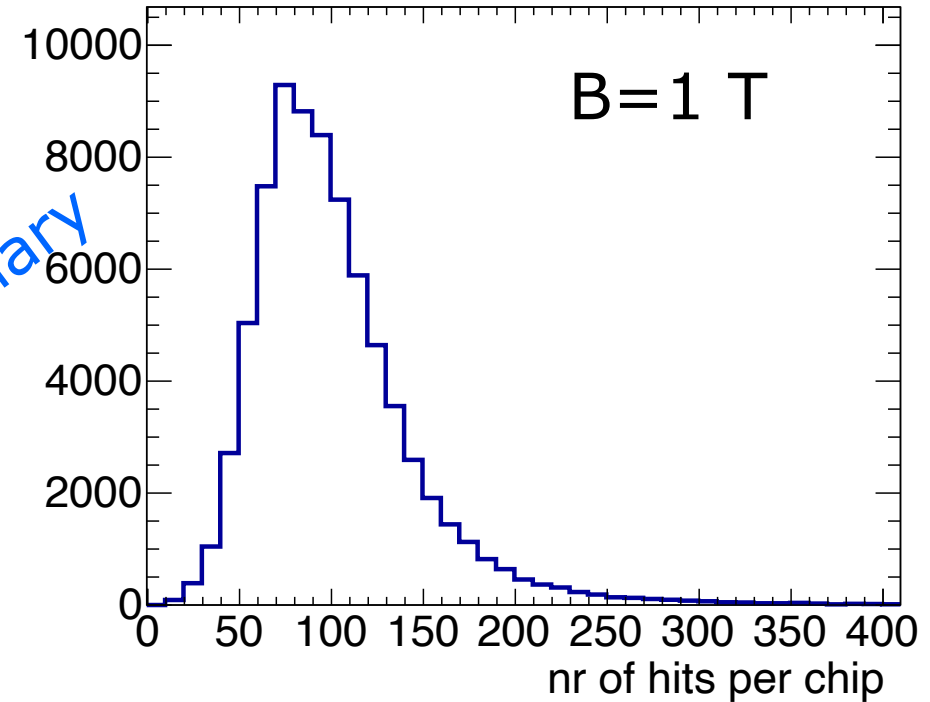
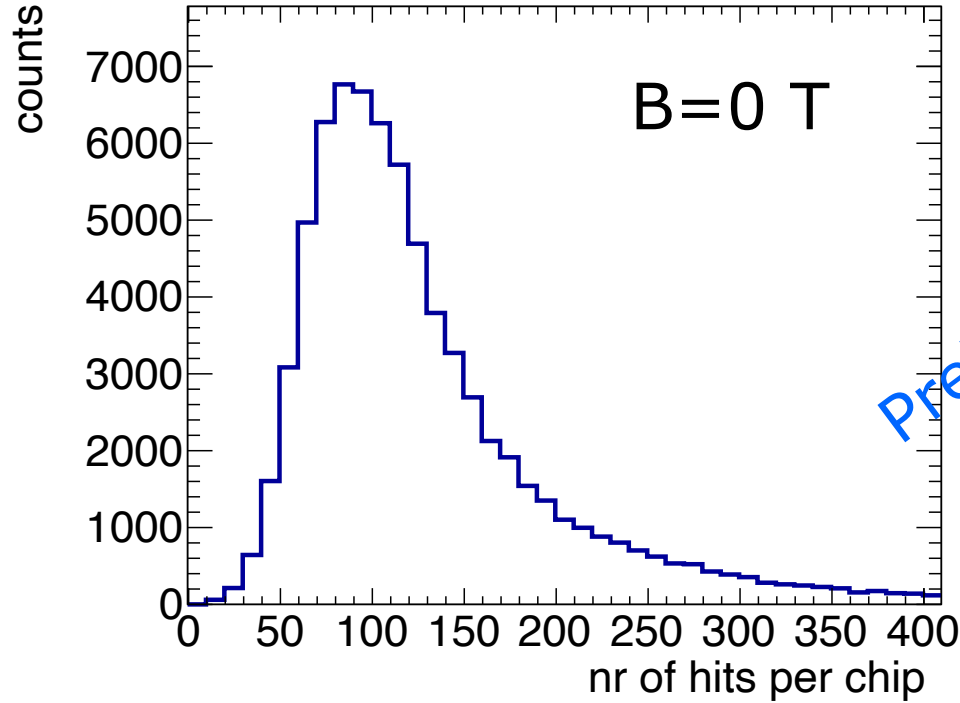

Preliminary

- B=0 T has a large Landau tail
- B=1 T smaller Landau tail and a more gaussian distribution
- An electron crossing 8 chips in the module has about 1000 TX3 hits

- Combine chips to form a 1 m long track with 60 % coverage for electrons
- Method 1) reject large clusters and then run dEdx @ 90% using slices of 20 pixels along track (xy) (gives nr of selected hits). A large cluster has more than 6 hits in 5 consecutive pixels.
- Method 2) fit the slope of the N_{scaled} minimum distance (d) distribution with an exponential function ($N_{\text{scale}}(d)$ =defines the inverse weights):

$$N(d)_{\text{scaled}} = N_{\text{scale}}(d) N_{\text{observed}}(d)$$

$$N(d)_{\text{scaled}} \text{ is then fitted for each track with } N_0 \exp(-\text{slope } d)$$
- Calculate the “dEdx” variable for electrons and MIP (==70% of hits)
 - method 1 = nr of selected hits, method 2 = slope
 - Resolution is $\sigma = \sigma(\text{dEdx})/\text{dEdx}$ (for σ we use the rms)

dEdx performance method 1

Electron resolution
3.6%
1 m track 60% and
coverage

Linearity MIP-e = 1.03
z drift=5-15 mm (flat)

MIP distribution is obtained
by dropping 30% of the hits

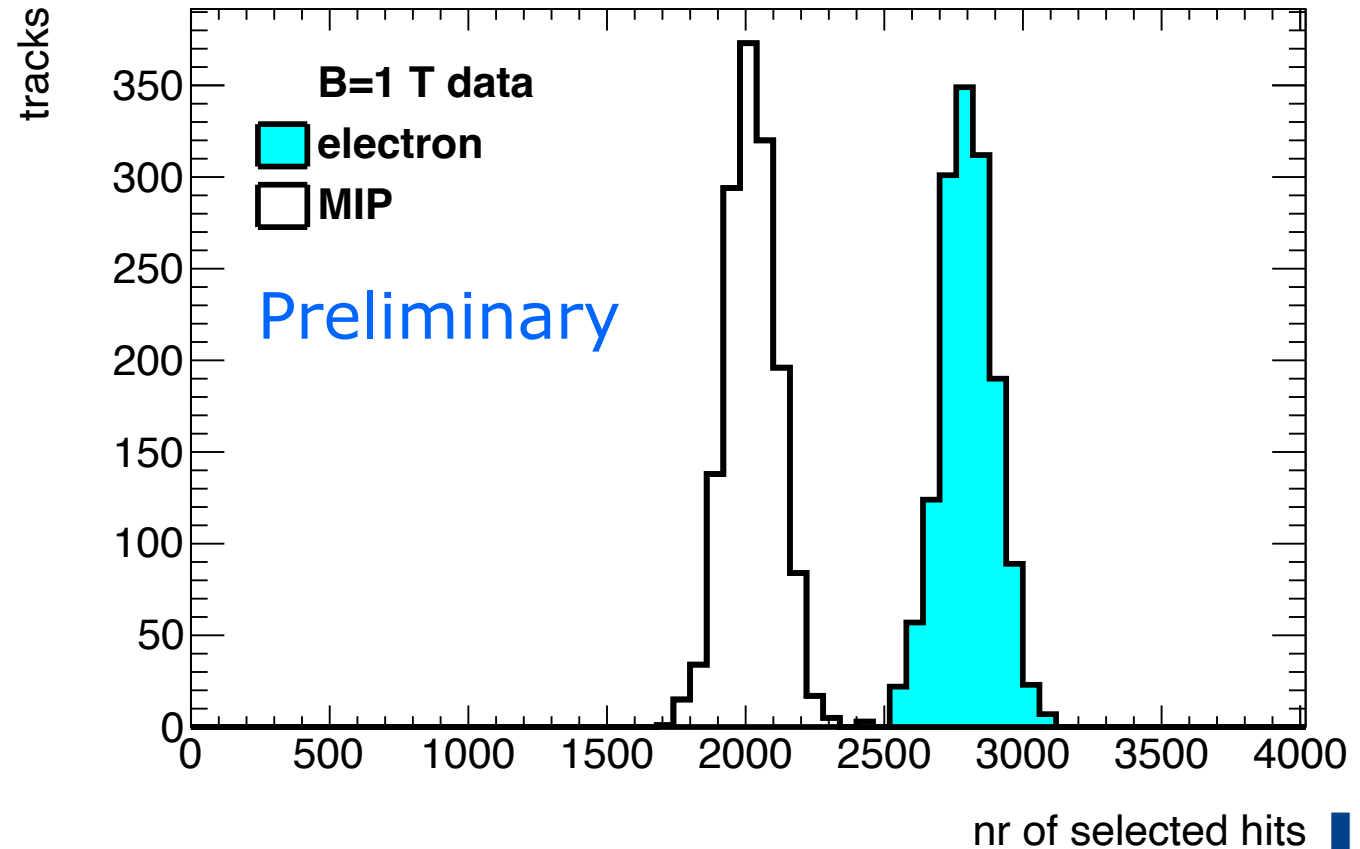

dEdx performance method 2

Electron resolution
2.9%

1 m track 60% and
coverage

Linearity MIP-e = 1.07

Ideally this is 1. A number
larger than 1 means that
the resolution is +7% larger

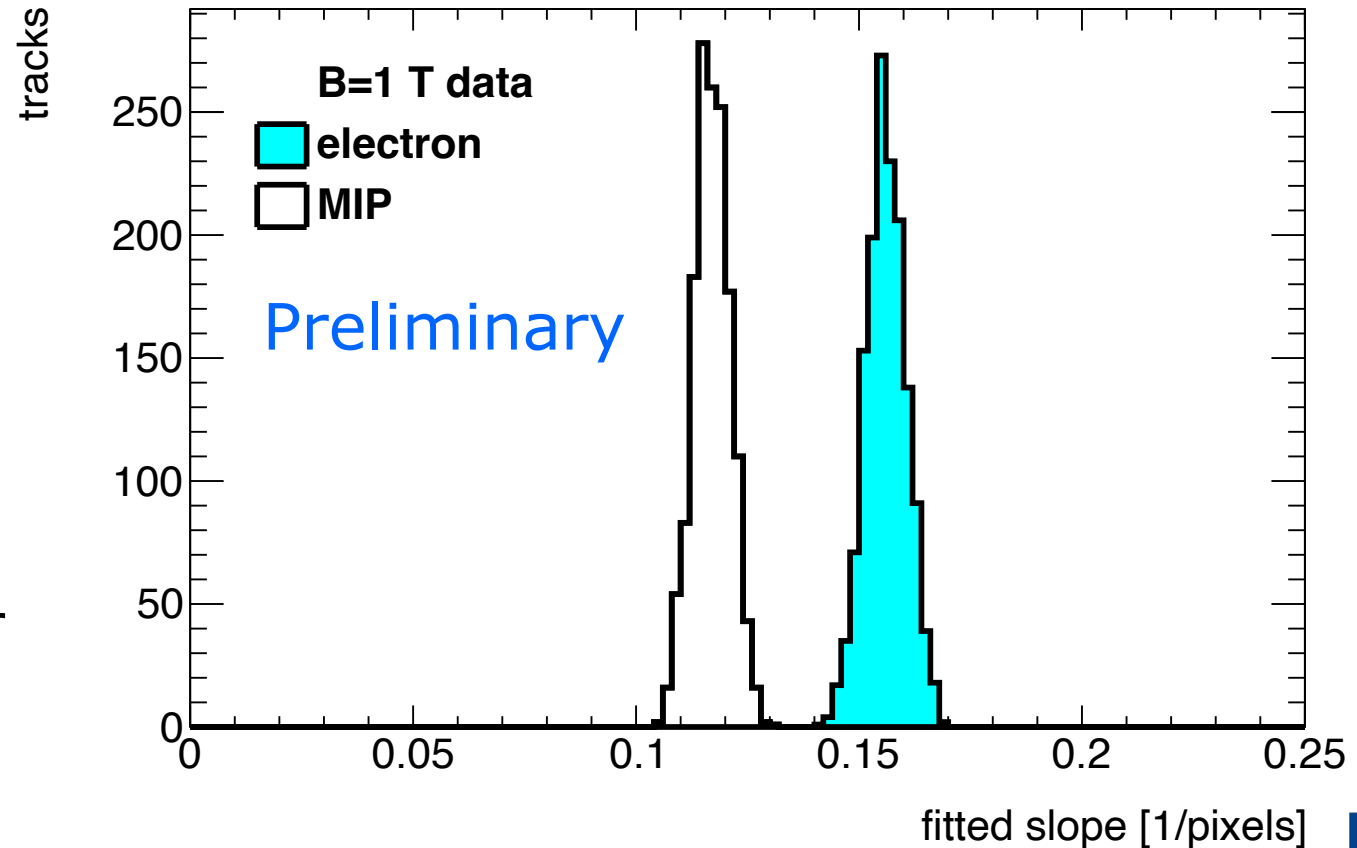

Summary of performance of dEdx

The dEdx resolution for electrons from data by combining tracks to form a 1 m long track with realistic coverage $\sim 60\%$ coverage.

Method	B=0 Resolution (%)	B= 1 T Resolution (%)
(1) dEdx 90 tail	6.0	3.6
(2) Fit slope	5.4	2.9

The “dEdx 90 tail” method is truncation at 90% where large clusters are identified and removed (tail reduced)

For the “Fit slope” method (2) an exponential distribution (with the slope and amplitude as free parameters) is fitted to the distribution of distance between the hits (as discussed: after applying the weights)

Preliminary

dEdx Performance extrapolated to CEPC detector

Test beam $B = 1 \text{ T}$
 $p = 5,6 \text{ GeV}/c$

Method 2 fit slope of the
distance distribution

electron resolution 2.9%

1 m track 60% and
coverage

CEPC TPC

$r_{\text{Inner}} = 600 \text{ mm}$ $r_{\text{Outer}} = 1800 \text{ mm}$

electron resolution = 2.65%
at $\theta = \pi/2$ ($\cos\theta = 0$)

Assume Pixel TPC performance at
 $B = 1 \text{ T}$ at $p = 5,6 \text{ GeV}/c$



dEdx performance for T2K gas

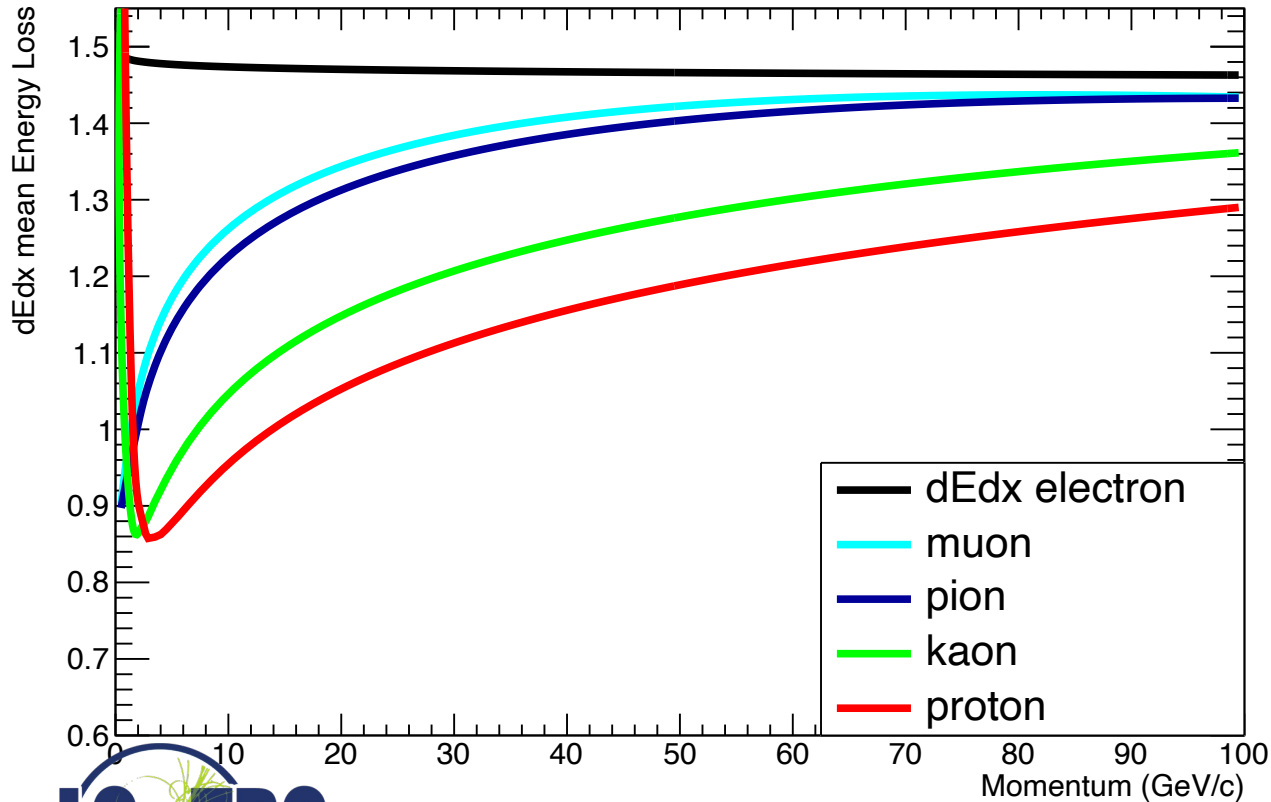

- Contacted Ullrich Einhaus for dEdx studies in ILD
- Extracted the ILC soft parametrisations for energy loss based on G4 and full simulation of the ILC TPC with T2K gas
- [Link](#) generated in 2020 with ILC soft v02-02 and v02-02-01

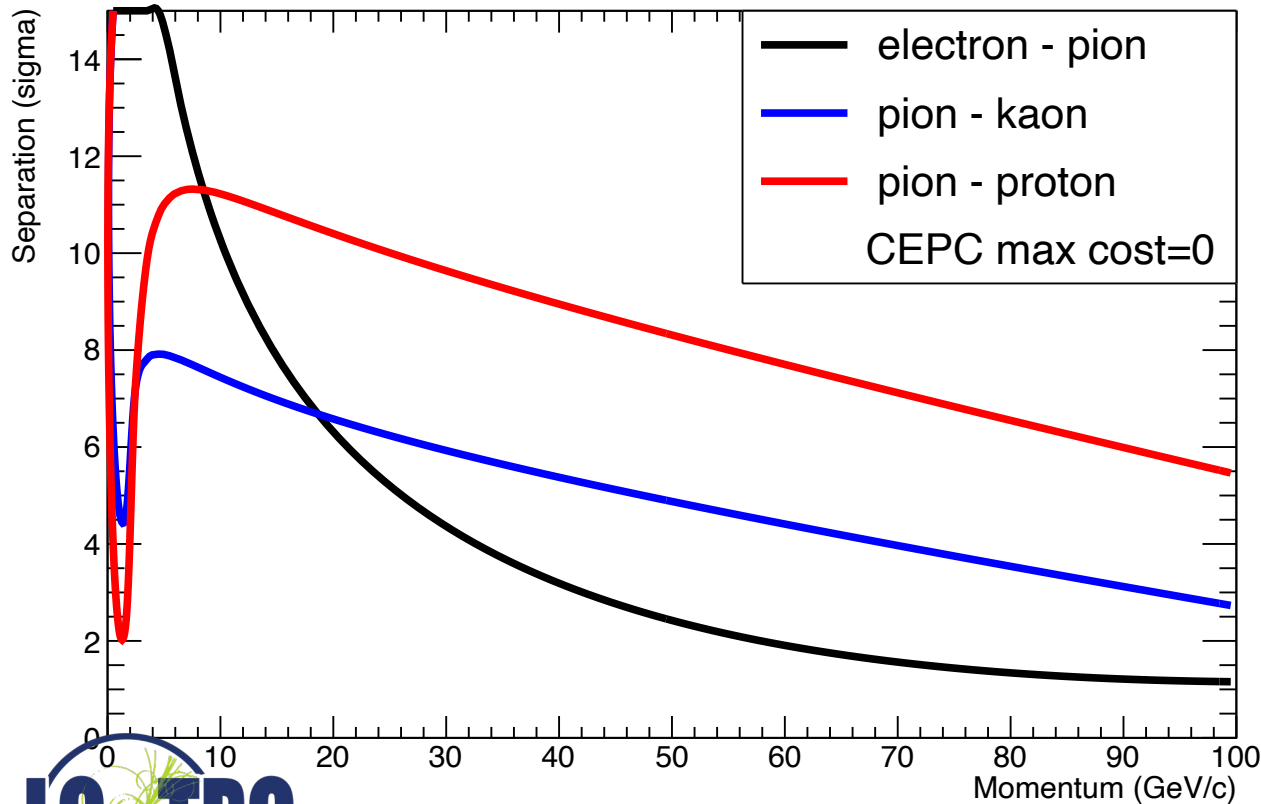

- Pixel TPC resolution from electron $p = 5$ (6) GeV test beam (for $B = 1$ T) of 2.65% - the 'max' scenario $\cos \theta = 0$
- Resolution scales as:

$$1/\sqrt{\text{track length} \langle \text{Eloss} \rangle}$$

- Separation electron pion
 $|\langle \text{Eloss } e \rangle - \langle \text{Eloss } \pi \rangle| / \sigma_{\pi}$
- Separation pion kaon
 $|\langle \text{Eloss } \pi \rangle - \langle \text{Eloss } K \rangle| / \sigma_{\pi}$

Fantastic performance more than 5σ K- π separation at 45 GeV/c

Pixel TPC dEdx performance

Worst case (diffusion) CEPC Performance with: 3.4% and 3.5% (2T) at $\cos \theta = 0$

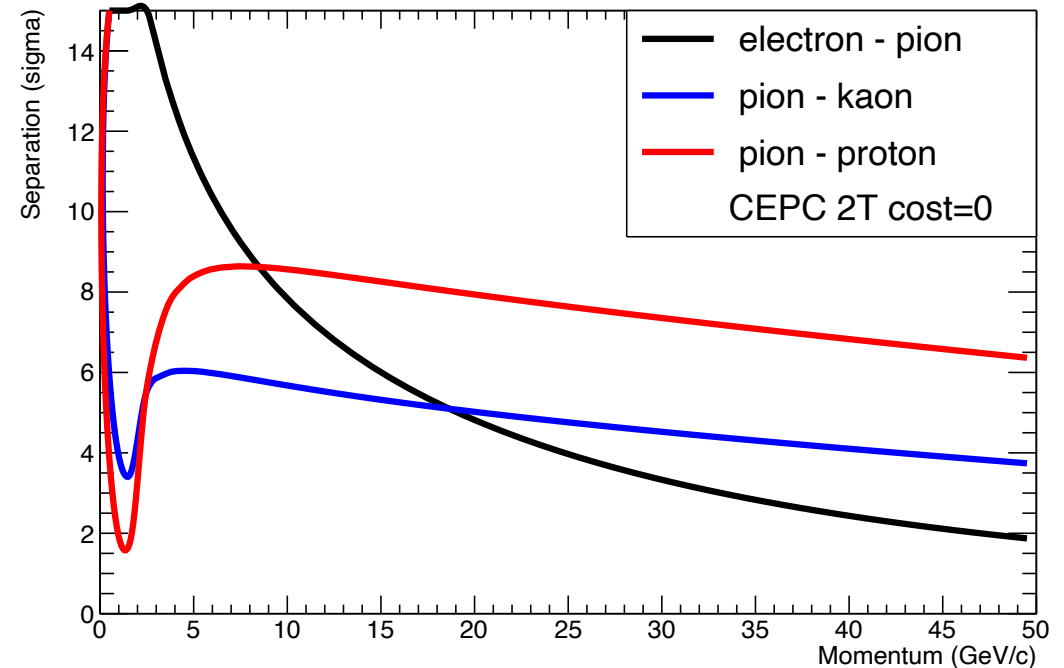
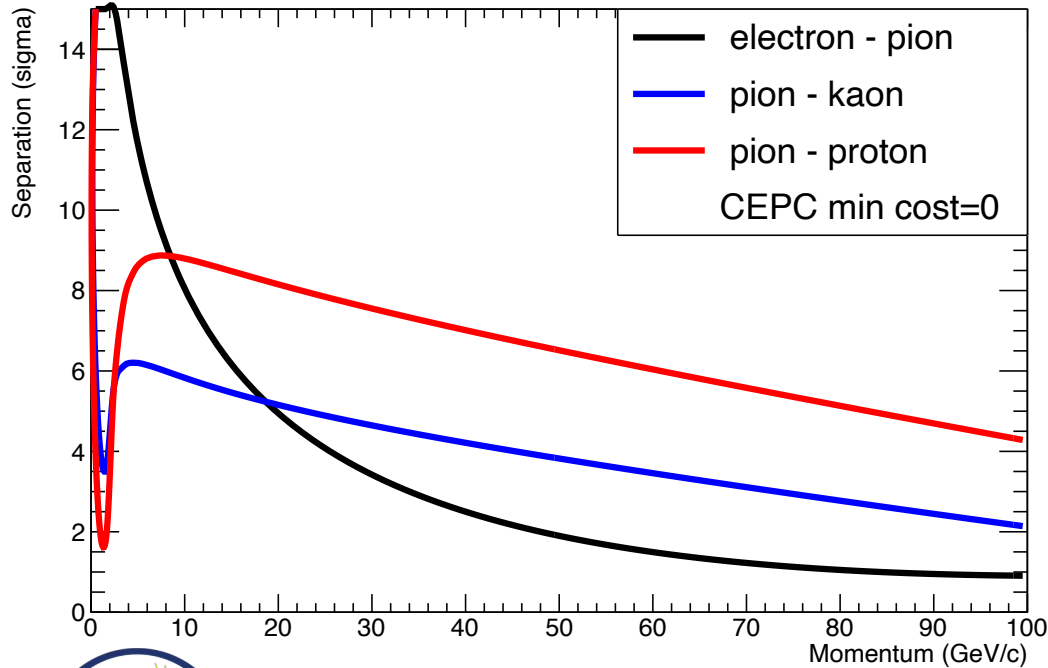

Worst case: $p = 45 \text{ GeV/c}$ π -K separation 4.0 (3T) and 3.9σ

- dE/dx resolution for an electron with $p=5,6$ GeV/c of 1 m track length with 60% coverage is measured to be 2.9% (at $B = 1$ Tesla)
- The resolution for the CEPS detector is 2.65% (w.c. 3.4% @ 3T and 3.5% @ 2T)
- This allows for particle identification and separation of Kaons from pions up to momenta of 45 GeV with more than 5σ (worst case 4σ and 3.9σ (2T)) for $\cos\theta = 0$. The separation increases up to $\cos\theta = 0.85$ (see back up slide).
- A test beam @ FermiLab with a quad in a TPC is planned (2024, US Grant EIC)
 - an EIC R&D program for CO2 cooling is funded (2023) (Yale, Stony Brook, Purdue, Bonn, Nikhef)
 - Focus is particle identification and tracking at the Electron-Ion-Collider
- A pixel TPC has become a realistic viable option for experiments
 - High precision tracking like ILD@ILC in the transverse and longitudinal planes, dE/dx by electron and cluster counting, excellent two track resolution, digital readout that can deal with high rates

Operation of a Pixel TPC at CEPC or FCC-ee

A Pixel TPC at CEPC or FCC-ee

The most difficult situation for a TPC is running at the Z.

At the Z pole with $L = 200 \cdot 10^{34} \text{ cm}^{-2} \text{ s}^{-1}$ Z bosons will be produced at $\sim 60 \text{ kHz}$

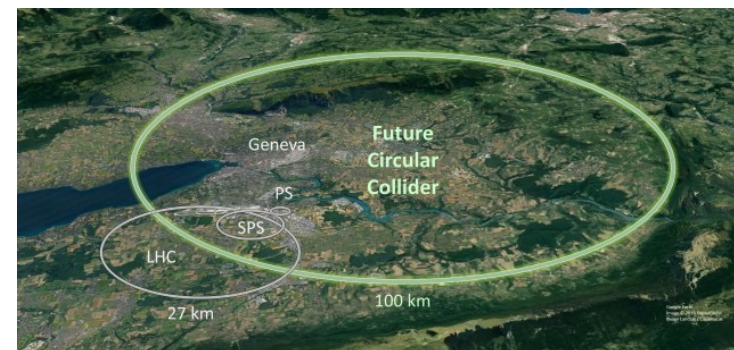
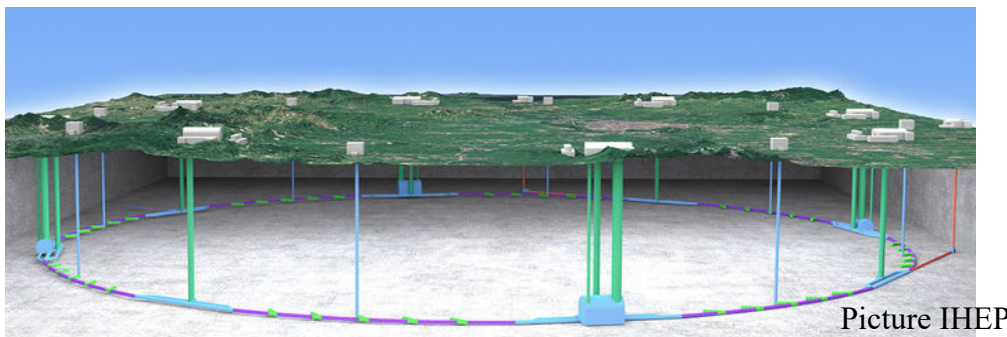

■ Can a pixel TPC reconstruct the events?

- The TPC total drift time is about $30 \mu\text{s}$
- This means that there is on average 2 event / TPC readout cycle
- YES: The excellent time resolution: time stamping of tracks $< 1.2 \text{ ns}$ allows to resolve and reconstruct the events

■ Can the current readout deal with the rate?

- Link speed of Timepix3 (in Quad): 2.6 MHits/s per $1.41 \times 1.41 \text{ cm}^2$ Testbeam up to 1.5 kHz
- YES: This is sufficient to deal with hits from Z's in high luminosity Z running
- NB: Data size is not a show stopper as e.g. LHCb experiment shows using the VeloPix chip

A Pixel TPC at CEPC or FCC-ee

- What is the current power consumption?
 - No power pulsing possible at these colliders (at ILC power pulsing was possible)
 - Current power consumption TPX3 chip $\sim 2\text{W}/\text{chip}$ per $1.41 \times 1.41 \text{ cm}^2$
 - So: good cooling is important but in my opinion no show stopper
 - For Silicon detectors lower consumption for the chips and cooling is an important point that needs R&D (e.g. microchannel cooling).
 - To save power the TPX3/4 chips can be run in LowPowerMode: reduction factor 10.
- Can one limit the track distortions?
 - There are two important sources of track distortions:
 - the distortions of the TPC drift field due to the primary ions
 - the distortions of the TPC drift field due to the ion back flow (IBF)
 - At the ILC gating is possible; for CEPC or FCC-ee this is more involved, for a Pixel TPC a double grid is the best solution (see next slide)

A Pixel TPC at CEPC or FCC-ee

- **Is it possible to reduce the IBF for a pixel TPC?**
 - IDEA: by making chip with a double grid structure (see back up slide)
 - This idea was already realized as a TWINGRID NIMA 610 (2009) 644-648
 - For GEMs for the ALICE TPC this was also the way – several GEMs on top of each other to reduce IBF
 - For the Pixel the IBF can be easily modelled and with a hole size of 25 μm an IBF of $3 \cdot 10^{-4}$ can be achieved and the value for $\text{IBF} \cdot \text{Gain} (2000)$ would be 0.6.
 - YES: the IBF can be reduced to 0.6 but this needs R&D
 - In the new detector lab in Bonn it is possible to make and study this device
- **What would be the size of the TPC distortions?**
 - Tera-Z studies by Daniel Jeans and Keisuke Fuji show that for FCC-ee or CEPC this means: distortions from Z decays up to $< O(100) \mu\text{m}$
 - Beam strahlung gives (now) a factor 200 more background. Detector optimization and shielding is important for TPC and Silicon detectors to reduce pair background.
 - It was argued that in an ILD like detector the distortions can be mapped out using the VTX-SIT/SET detectors.

Fitting out TPC distortions in ILD/CEPC

- It is possible to **map out distortions** using e.g. muons from Z decays
 - E.g. by fitting the 3D spatial distribution as a function of time as was done by ALEPH and more recently by ALICE. Using this distribution the hits positions are corrected and the TPC track refitted.
- However, with **silicon trackers around the TPC**, more elaborate methods can be used. One can use the track predictions based of the silicon trackers SIT and SET to correct on a track-by-track level the TPC track.
 - One can use as a constraint that the extrapolated positions and angles agree with the measured in the SIT and SET.
 - Practically, one can e.g. correct the TPC track parameters
- The ultimate way is a **fitting technique** similar to ATLAS. In the ATLAS track fit the common systematics is fitted out for sets of Muon hits. For ILD/CEPC the fit would fit free parameters in the distortion model, while using as a constraint the SIT and SET position and direction measurements.
 - The simplest case is a model where the strength (amplitude) and radial dependence would be scaled and a model is used for the 3D extrapolations.

Conclusions: Pixel TPC at a circular collider

- YES: a pixel TPC can reconstruct the Z events in one readout cycle
- YES: the current **readout** of the Timepix3 chip can deal with the Z hit rate running
 - The current MDI design FCCee/CEPC gives a lot of beam-beam background more than a factor 100 more hits from the beam than from the Z. This far from optimal. **An improved MDI is needed.**
- The current **power consumption** is $1\text{W}/\text{cm}^2$. By running the TPX chips in low power mode this can be reduced by a factor of **10**. Still good **cooling** is important no show stopper; but needs extensive R&D.
- Track distortions in the TPC drift volume are a concern at high lumi Z running:
 - Track distortions from Z decays in TPC are $O(100)\ \mu\text{m}$
 - It is possible to reduce the IBF for a pixel TPC by making a device with a **double grid**
 - A double grid needs dedicated R&D that can be performed in the new lab in Bonn
- The Z physics program at FCC-ee or CEPC with an ILD-like detector with a Pixel TPC (with double grid structures) sliced between two silicon trackers (VTX-SIT and SET) can be fully exploited. The reduction of beamstrahlung by an improved MDI – and the fitting out of distortions - needs more study.
- A pixel TPC can perfectly run at WW, ZH or tt energies where track distortions are several orders of magnitude smaller

Backup plots

Calculate minimum distance between the hits.

The slope of the distribution is related to the number of primary clusters /cm

The diffused peak at $d < 10$ comes from clusters with more than 1 hit.

Single chip

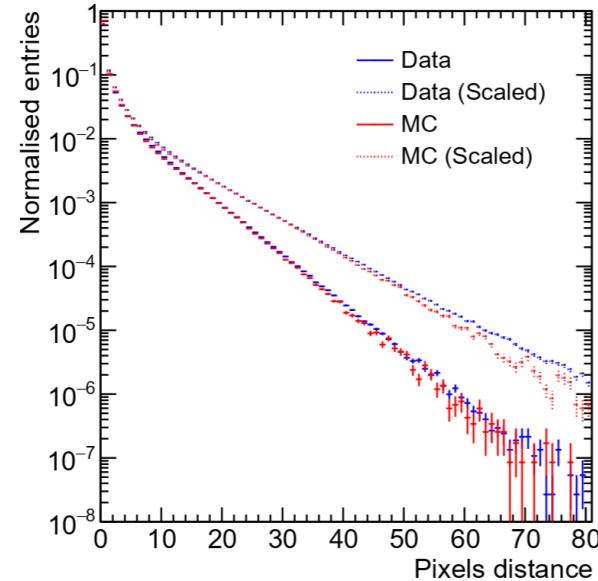

Quad module

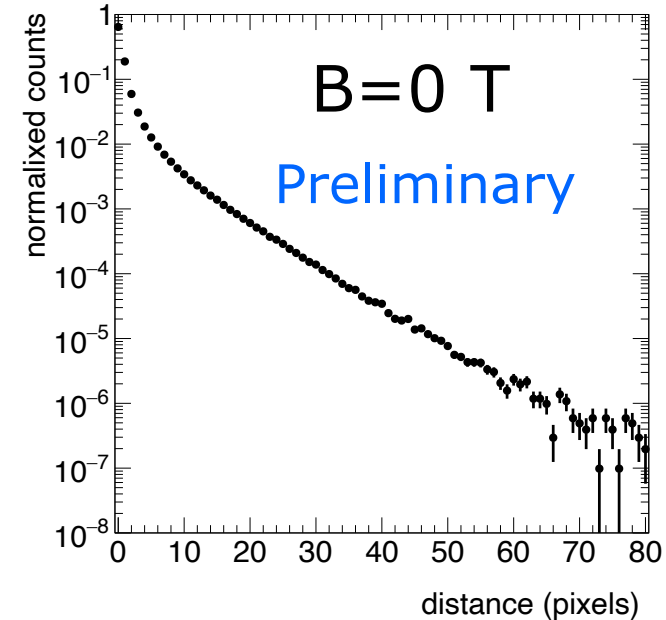
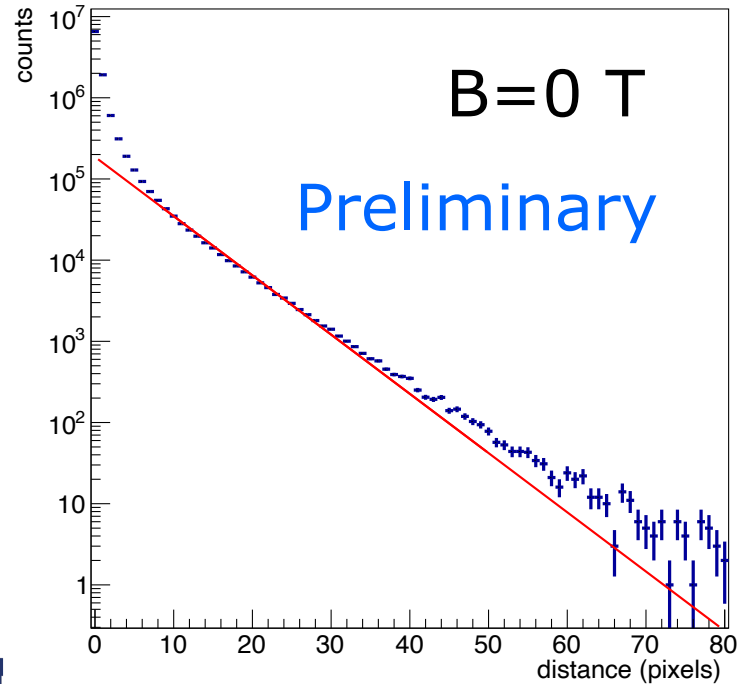

Figure 5.19: Distribution of distance between hits for a 2.5 GeV electron in pixels from test beam data (blue) and from a Monte Carlo simulation (red).

Thesis Kees Ligtenberg

Performance of dEdx

Method 2: Fit slope of the distance distribution



From 10 clusters onwards an exponential distribution is followed.

Below 10 the distribution will be down-weighted ($N_{\text{scale}}(d) = 1/\text{weight}$). The weights are:

Weights B=0 = { 35.0467 , 12.1497 , 4.52914 , 2.76311 , 1.99386 , 1.59795 , 1.3656 , 1.21409 , 1.11898 , 1.04385 };

Weights B=1 = { 22.5617 , 7.39573 , 2.43318 , 1.54528 , 1.23428 , 1.09727 , 1.04368 , 1.01625 , 1.00182 , 0.998178 };

Note the difference in weights in the B=0 and 1 T data sets. This is related to the fluctuations

Pixel TPC dEdx performance

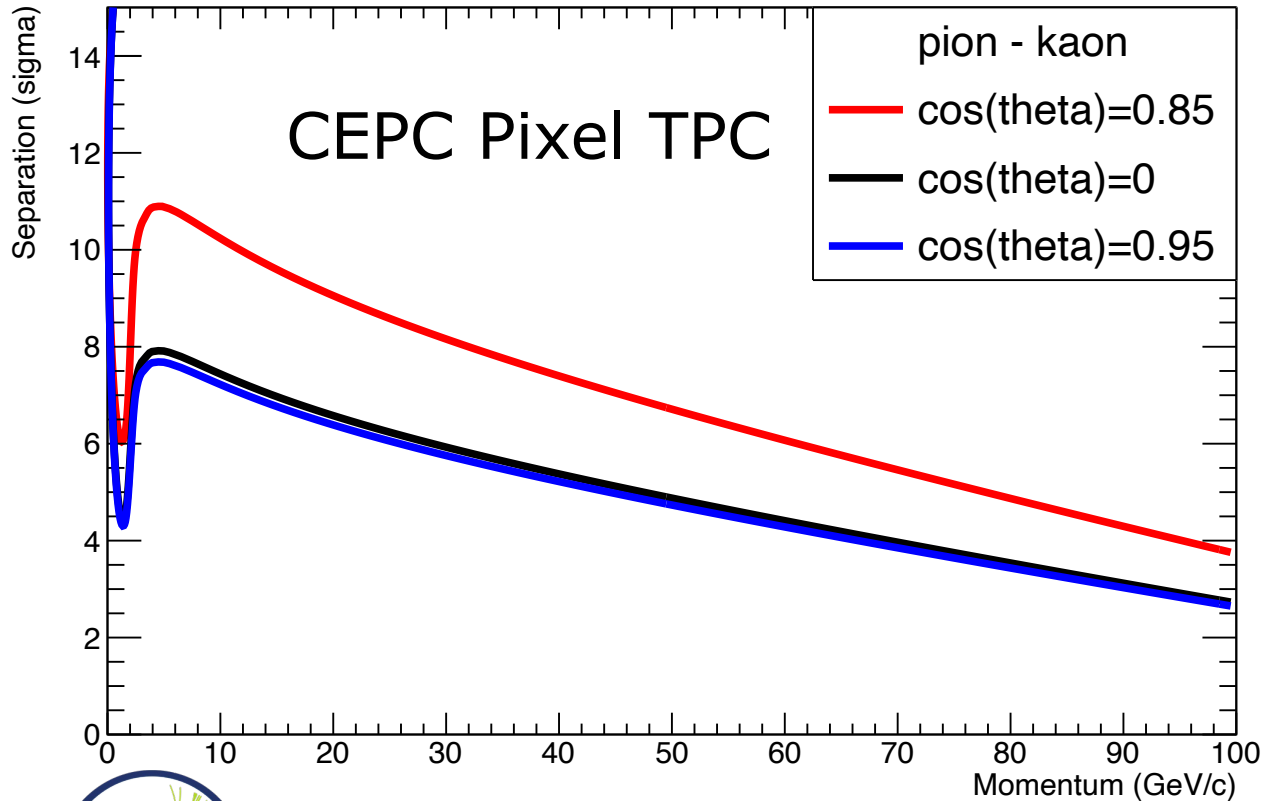

- Separation pion kaon

$$| \langle E_{loss} \pi \rangle - \langle E_{loss} K \rangle | / \sigma_{\pi}$$
- Separation pion kaon for different cos(theta) values due to the track length dependence
- For cos(theta)=0 till 0.95 the separation lies between the black and red curves. Only above 0.95-0.975 the separation drops till the blue curve.
- 'max' scenario with resolution 2.5%
- Excellent performance over very large polar angle range

Reducing the Ion back flow in a Pixel TPC

The Ion back flow can be reduced by adding a second grid to the device. It is important that the holes of the grids are aligned. The Ion back flow is a function of the geometry and electric fields. Detailed simulations – validated by data – have been presented in [LCTPC WP #326](#).

With a hole size of 25 μm an IBF of $3 \cdot 10^{-4}$ can be achieved and the value for IBF*Gain (2000) would be 0.6.

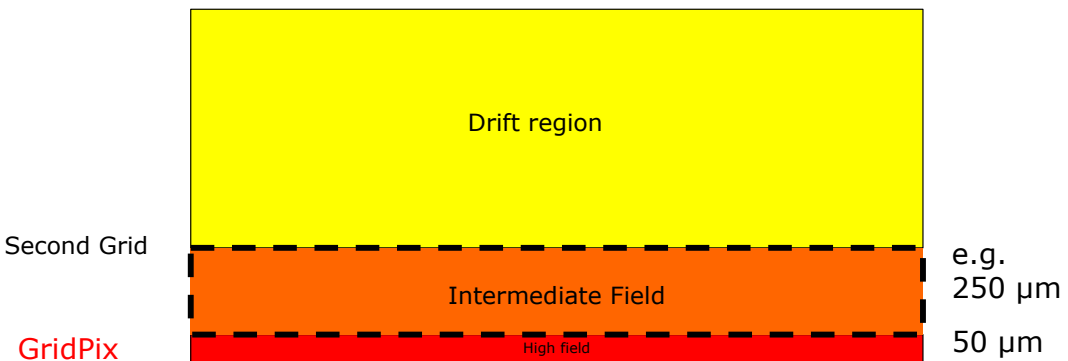

Ion backflow	Hole 30 μm	Hole 25 μm	Hole 20 μm
Top grid	2.2%	1.2%	0.7%
GridPix	5.5%	2.8%	1.7%
Total	$12 \cdot 10^{-4}$	$3 \cdot 10^{-4}$	$1 \cdot 10^{-4}$
transparency	100%	99.4%	91.7%